

PROTECTOWIRE® *FireSystem* SRP4x4

STANDARD RELEASE PANEL OPERATING & MAINTENANCE MANUAL



IMPORTANT SERVICE NOTICE

When requesting service assistance, or to order parts for this control panel, you are required to provide the **Model Number, Drawing Number and Serial Number**. This product information is recorded on the Panel Identification Label located inside the control panel. Please have this information available before calling your Authorized Protectowire Distributor or the Factory.

Table of Contents

General Information & Panel Specification

Company Information / Publishing Date	2
Notice & Warnings.....	3
System Description & Features.....	4
Systems Specifications.....	5 - 6

Enclosure Information

Enclosure Dimensions.....	7 - 9
Panel Mounting.....	10
Battery Cabinet Mounting.....	11

Wiring

Wire Routing Detail (Power Limited vs Non-Power Limited).....	12
Wire Size Estimator.....	13
Field Wiring (Initiating Device Circuits).....	14
Field Wiring (NAC & Solenoid Release Circuits).....	15

Options

Alarm Point Location Meter (PDM-1000-4).....	16
Auxiliary Relay Module (RB-4).....	17
Class A Alarm Notification Module (AM-91-2).....	18

Installation / Troubleshooting

Installation Test & Maintenance.....	19
Troubleshooting.....	20 - 24

Programming

Wire Diagram Program Chart.....	25 - 39
---------------------------------	---------

Battery Calculations

Battery Size Selection Chart.....	40
Panel Instructions (tearout).....	41

Appendix A

Listed Solenoids, Notification Appliance Devices, Listed Smoke Detectors.....	42 - 44
---	---------



PROTECTOWIRE®
FireSystem
SRP4x4

The Protectowire Co., Inc.
60 Washington Street, Pembroke, M
U.S.A. 02359-1833

**Model SRP-4x4 Standard Release Panel
Operating & Maintenance Manual**

Man-2002 Rev. B
Publish Date 2-5-14

Notice

TESTING AND MAINTENANCE OF SYSTEM CONTROLS SHALL BE PERFORMED BY COMPETENT PERSONNEL HAVING JURISDICTION OVER THIS PROTECTIVE SIGNALING SYSTEM.

TESTING ZONES WITH SOLENOID RELEASE CIRCUITS AND EQUIPMENT SHUTDOWN CONTACTS MAY BE ACCOMPLISHED BY USE OF A JUMPER WIRE ACROSS EACH DETECTION / INITIATING CIRCUIT FIELD WIRING TERMINALS ONLY AFTER THE OUTPUT DISCONNECT SWITCH, LOCATED IN THE LOWER LEFT CORNER OF MAIN BOARD, HAS BEEN PLACED IN THE LEFT POSITION. SLIDING THIS SWITCH IN THE LEFT POSITION ALLOWS OUTPUT SIGNALS FOR OP2, OP3, AND OP4 TO BE BYPASSED.

NOTE: IT IS ALWAYS GOOD PRACTICE TO DISCONNECT ALL PRE-ACTION SYSTEMS PRIOR TO TESTING.

WARNING!

FATAL ELECTRICAL SHOCK AND EQUIPMENT
DAMAGE MAY RESULT FROM FAILURE TO REMOVE
ALL POWER PRIOR TO SERVICING SYSTEM.

CAUTION

The Protectowire Co., Inc. designs and manufactures fire protection systems to meet both UL and FM Global criteria for electrical transients introduced on both the power supply side of the system and into the panel from field wiring for initiating device circuits, notification appliance circuits, and other external field routed wiring.

Fire protection systems located in areas subject to lightning strikes, or subject to other severe transients, and electromagnetic interference, should be protected similar to computers and other electronic systems with supplemental surge and filter protection both on the power supply side and on field wiring for initiating device circuits, notification appliance circuits and other field routed wiring.

Please refer to surge/filter manufacturers, (eg., DITEK 800-753-2345, www.ditekcorp.com) to specify devices for your particular conditions. The National Lightning Safety Institute (www.LightningSafety.com) also provides valuable information regarding the problems and solutions of providing lightning protection including assuring true earth ground conditions.

Lightning strikes, other severe power surges, and significant EMI/RFI interference, by their nature, are beyond normal design criteria and are outside the warrantee for manufacturing defects.

MODEL SRP-4x4

STANDARD RELEASE PANEL

System Description & Setup

The Model SRP-4x4 is a Fire Alarm Control/Releasing Panel which is FM approved, UL Inc. Listed. It is designed primarily for use as a releasing panel for Pre-action and Deluge, water based extinguishing systems. This unit is in compliance with NFPA-13, NFPA-72, and UL864 and can be used as a stand alone Fire Control Panel.

The Fire Control Panel is programmable by way of three (3) eight (8) position DIP switches. Select a system programming scheme that meets your requirements as depicted on pages 25 thru 39. *Special attention must be taken in positioning dip switches for proper panel operation.*

System Features

Four (4) Supervised Class A (style D) or Class B (style A or B) Initiating device circuits which may be configured for the following functions.

1. Standard Initiating Device Circuits Compatible with the following:
 - a. Up to 10,000 Feet (3,048m) of Protectowire type PHSC linear heat detector.
 - b. Up to 20 (45uA) Hochiki smoke detectors.
 - c. Any combination of Normally Open contact initiating devices.Examples: Conventional Manual Pull Stations, Waterflow Switches, Conventional Spot heat detectors.
2. Supervisory Initiating Device Circuits Compatible with the following:
 - a. Any combination of Normally Open contact initiating devices.Examples: Low air pressure switches, Valve Tamper Switches.

Four (4) Supervised Class B (Style Y) Output Zones: Each Output can be set up for any of the following:

- 1) Notification Appliance Circuit (Output #1 thru #4)
- 2) Release circuit (Outputs #2, 3, and/or 4)
- 3) Supervisory Bell circuit (Outputs #3 & 4 only)
- 4) Trouble Bell circuit (Output #4 only)

- Releasing Zones can be set up for either single or cross zone operation
- All circuits are inherently Power-Limited per NFPA 70 (nec) see 760
- Initiating circuits can be wired as Class A or B
- Output circuits # 2, 3, and 4 have disable feature
- Signal Silence Button (common alarm and/or trouble conditions)
- System Reset Button
- Built-in Trouble/Supervisory Buzzer
- Auxiliary Contacts for Alarm/Trouble/Supervisory
- On Board 24V Auxiliary Power (100mA MAX) Resettable
- Ground Fault Detection (2.2K ohms to Ground)
- Battery Trouble circuit (low battery, battery overcharge, battery disconnect)
- 24 or 90 hour Battery Standby operation available Options:

- 1) AM-91-2 Module: converts Class B Notification Appliance circuit to Class A
- 2) PDM-1000-4 Protectowire Digital Alarm Point Location Meter.
- 3) RB-4 Auxiliary Alarm Relays

SPECIFICATIONS

Housing

Type: 16 gauge steel.

Door: Piano Hinged, lockable.

Dimensions: 20 1/2" x 14 1/4" x 4 3/4"

Finish: Red enamel with red, black and white logo/label.

Knockouts: Minimum of one 1/2" and two 3/4" knockouts on each side, top and bottom.

Visual Indicators

(Visible LED's with door closed)

AC-ON: (1) Green

System Silence, System Trouble, Ground Fault Detection, Battery Trouble, and Output

Disconnect Supervisory: (5) Yellow

Common Alarm: (1) Red

Supervisory Zone Alarm: (1) Yellow

Input and Output Zone Trouble: (9) Yellow

Input and Output Zone Alarm: (8) Red

Control Buttons

Signal Silence: Momentary - Silences alarm signaling circuits, trouble buzzer and outputs programmed as supervisory bell or trouble bell.

System Reset: Momentary - Resets all alarm circuits if condition has been corrected.
Removes power from initiating circuits.

Initiating Device Circuits (4 TOTAL)

4 NFPA Style D (Class A) or Style B (Class B)

Power-limited

IDC loop current (IDC): 1.1 mA.

IDC alarm trip current: 10 mA minimum.

IDC alarm current (short circuit): 44 mA max.

Normal loop voltage: 23 VDC

Linear heat detector resistance: 2000 ohms max.

Maximum Impedance to insure Alarm: 2.4K ohms.

End of Line Resistor: ELR-8.2K (Required in Class B configuration only)

Two Wire Detector capacity (per zone): 20 - 0.045 mA type Hochiki smoke detectors

Low/Disconnected Battery

Battery and system trouble indication when voltage falls out of range between 21 -29 Volts, or has been disconnected

Fused battery and reverse polarity protection is provided.

Conditioning Resistor: 2.2 K ohm (Remove and replace with batteries)

SPECIFICATIONS *(continued)*

Output Circuit (4 TOTAL)

(ALARM INDICATING, RELEASING, SUPERVISORY AND TROUBLE BELL)

4 Supervised Notification Appliance Circuits (NAC) Class B, reverses polarity on alarm (Optional Class A Module: AM-91-2). Maximum line loss not to exceed 1.0 Volts or 1 Ohm fully loaded. Power-limited, each circuit has self-resetting type fuse (PTC).

Output #1; Dedicated for Notification Only; rated 24V FWR regulated, 1 amp continuous.

Outputs #2, 3 & 4 rated 24VDC regulated, 1 amp each, 2.1 amps combined for Solenoid activation.

Per UL listings circuits are rated .25 amps each, .75 amps combined for Notification Devices

Standby terminal voltage approximately -2.7VDC.

End of Line Resistor ELR-8.2K ohms.

Compatible Solenoids: FM Solenoid Groups A, B, D, E, F, G, I, J & K

For UL see Appendix A for compatible Solenoids.

Supervisory Circuit (1 TOTAL)

Supervisory monitors the following:

High/Low Air

Tamper/Valve positioning and etal

One latching Class B Supervised Initiating Device Circuit.

Power-limited.

End of Line Resistor ELR-8.2K ohms.

Circuit loop resistance 100 ohms.

Increase in circuit resistance causes supervisory trouble and system trouble.

Maximum resistance for supervisory signal 2200 ohms to insure alarm.

Minimum current 4.5 mA to insure alarm (10 mA short circuit maximum).

Normal supervisory standby loop current 2 mA.

Normal standby loop voltage 19.5VDC.

Input Power

120VAC - 1.37 Amp max. (50-60 Hz) or 240VAC - .85 Amp max. (50-60 Hz)

Green AC-ON LED goes off with AC power loss, causes system trouble and buzzer to sound.

System on battery backup.

System Trouble is also generated if voltage drops below 102V under alarm load, system is transferred to battery backup.

Power Requirements

Standby - 160 mA @ 24VDC, 7.0 AMP Batteries for 24 hour standby

- 160mA @ 24VDC, 18.0 AMP Batteries for 90 hour standby (FM Requirement)

Alarm - 3.5 AMP MAX. @ 24VDC All Zones.

Battery Charger Specifications: 27 VDC @ 1.2mA trickle; 1 Amp fast charge.

33 AH Battery maximum, sealed rechargeable type.

Outputs

System Remote Signaling Relay contacts rated 3A, 30VDC (resistive) for Alarm, Supervisory & Trouble.

Auxiliary Power - 24VDC regulated. Rated 100mA max. Power-limited. (Resettable)

ENCLOSURE DIMENSIONS

IMPORTANT: The stated dimensions are for the enclosure back box only and do not account for the overall dimensions of the enclosure with the door installed. To account for the enclosure door and hinges add an additional 0.4" to the back box width, and 0.08" to the depth.

Caution: Do not drill through the top of the enclosure for conduit entry. Metal filings will damage system components and voids factory warranty. Use knockouts provided and seal all conduit openings to prevent water ingress.

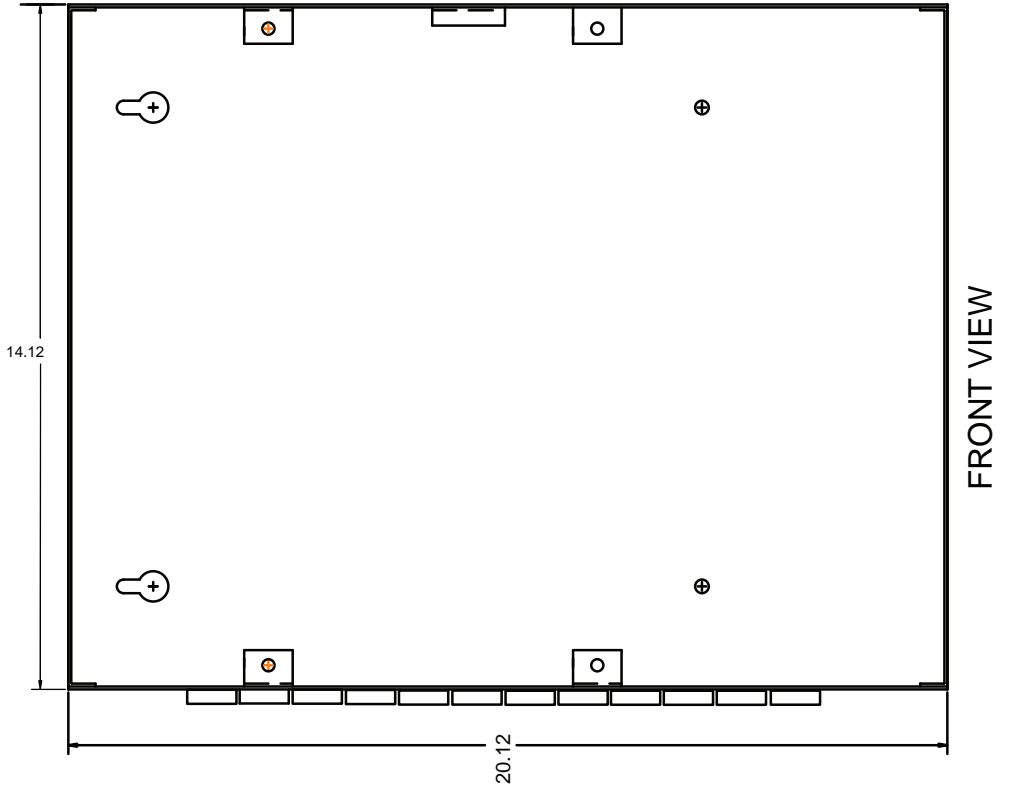
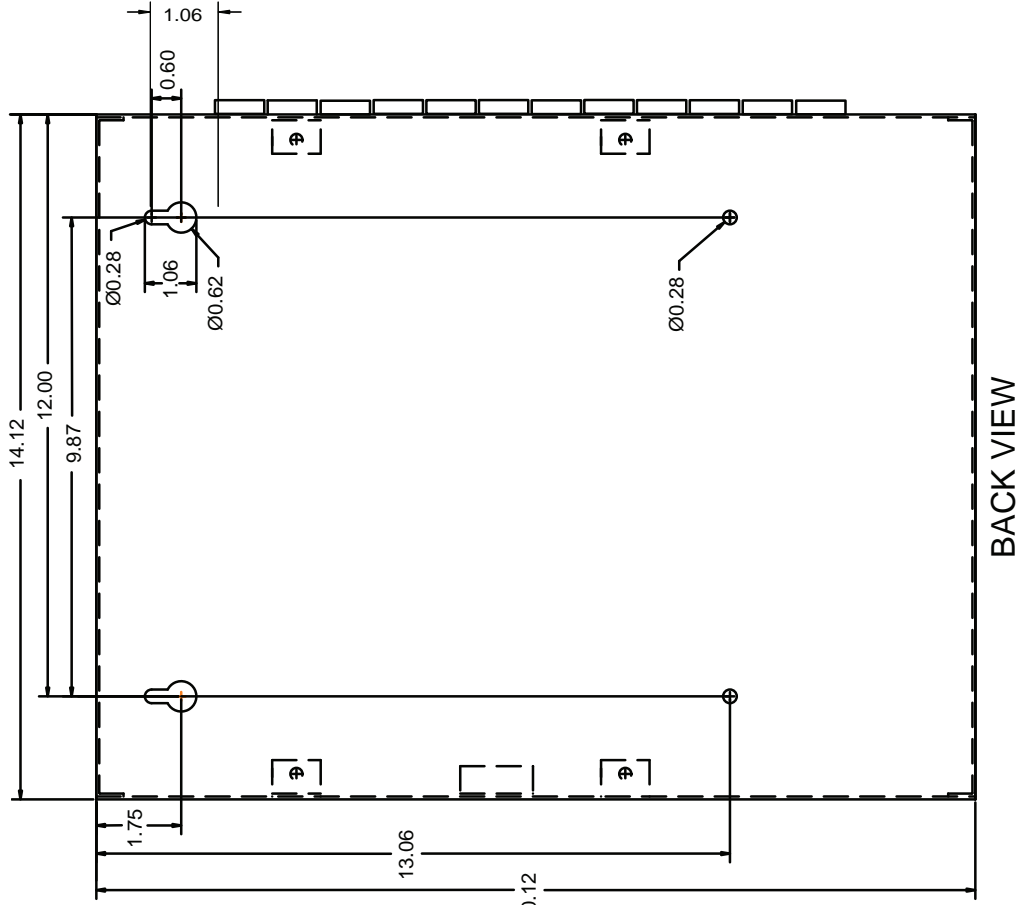
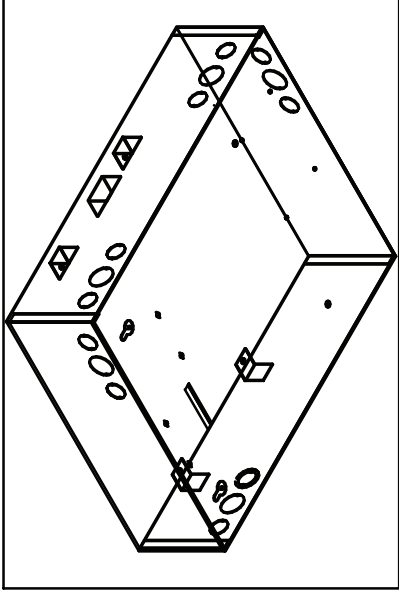

ENCLOSURE DIMENSIONS

IMPORTANT: The stated dimensions are for the enclosure back box only and do not account for the overall dimensions of the enclosure with the door installed. To account for the enclosure door and hinges add an additional 0.4” to the back box width & height, and 0.08” to the depth.

Caution: Do not drill through the top of the enclosure for conduit entry. Metal filings will damage system components and voids factory warranty. Use knockouts provided and seal all conduit openings to prevent water ingress.

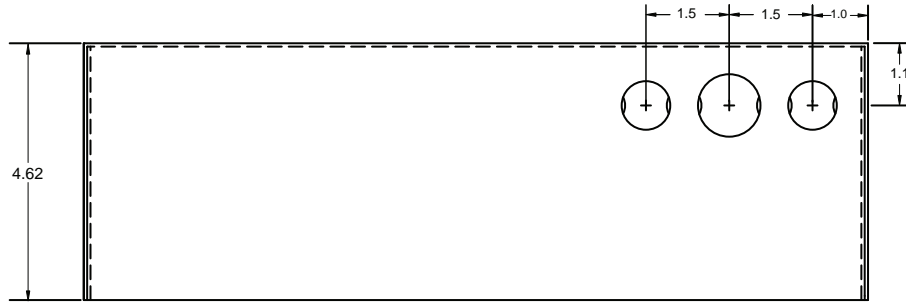

TOP/BOTTOM VIEW

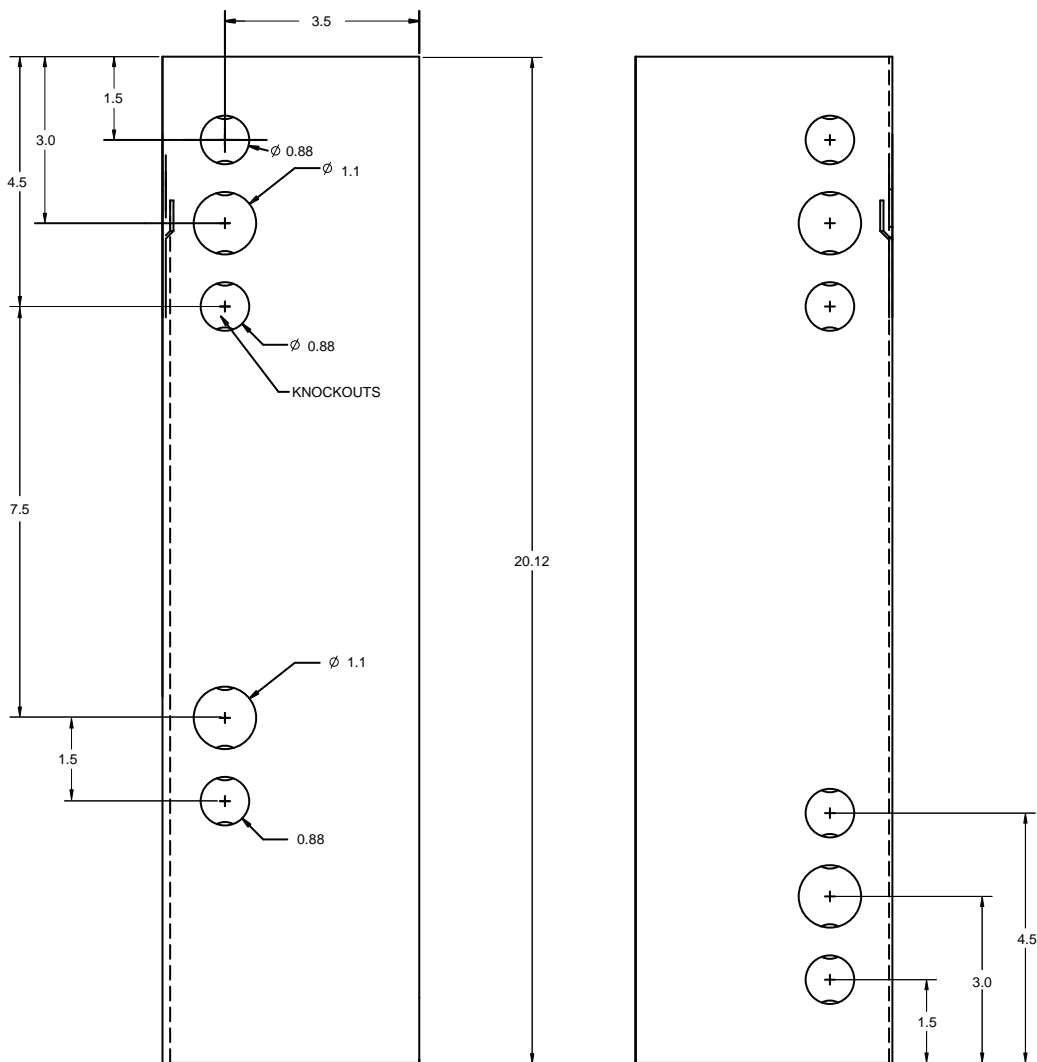

LEFT/RIGHT SIDE VIEW

ENCLOSURE DIMENSIONS

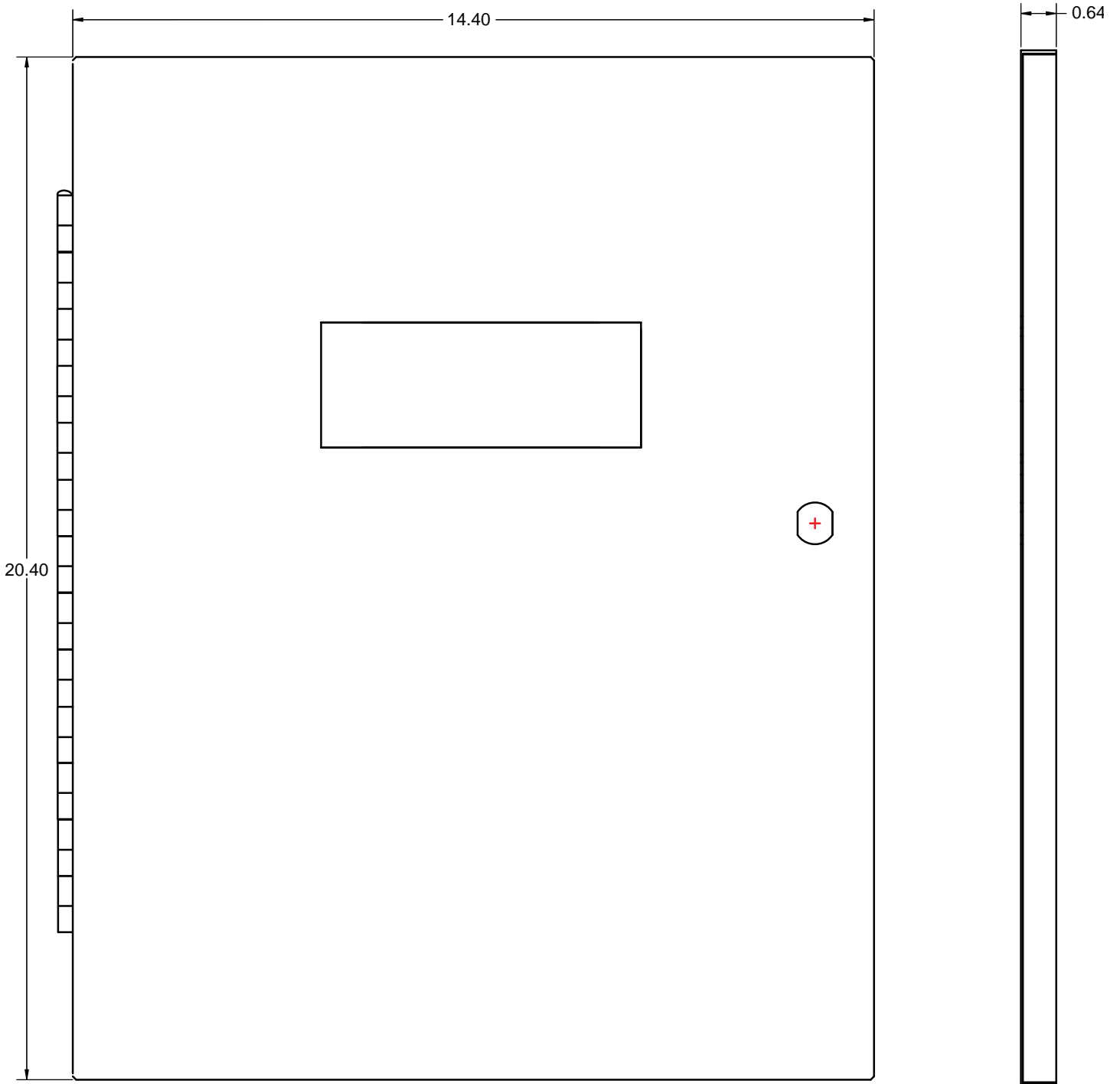

DOOR FRONT/SIDE VIEW

PANEL MOUNTING

- Panel shall be located in a clean, dry, vibration free environment. Panel shall not be subjected to extreme temperatures or humidity.

- Panel shall be *wall mounted* only, with the top of enclosure at a height of 6 feet. Secure the panel using the mounting holes provided.

- The panel must be easily accessible for maintenance with no physical obstructions blocking it's access or visual operation.

- The panels hinged door requires an additional 16 inches of free space. This additional space allows the front door to be fully swung open.

- Do not drill through the top of the enclosure for conduit entry. Metal filings will damage system components and voids factory warranty. Use knockouts provided and seal all conduit openings to prevent water ingress.

- Once panel has been mounted connect all required conduit, field wiring, detection circuits, audible devices and/or solenoid valves. Lastly connect input and battery back-up power.

- Follow the Installation, Testing and Maintenance procedure for complete testing and operations of installed system.

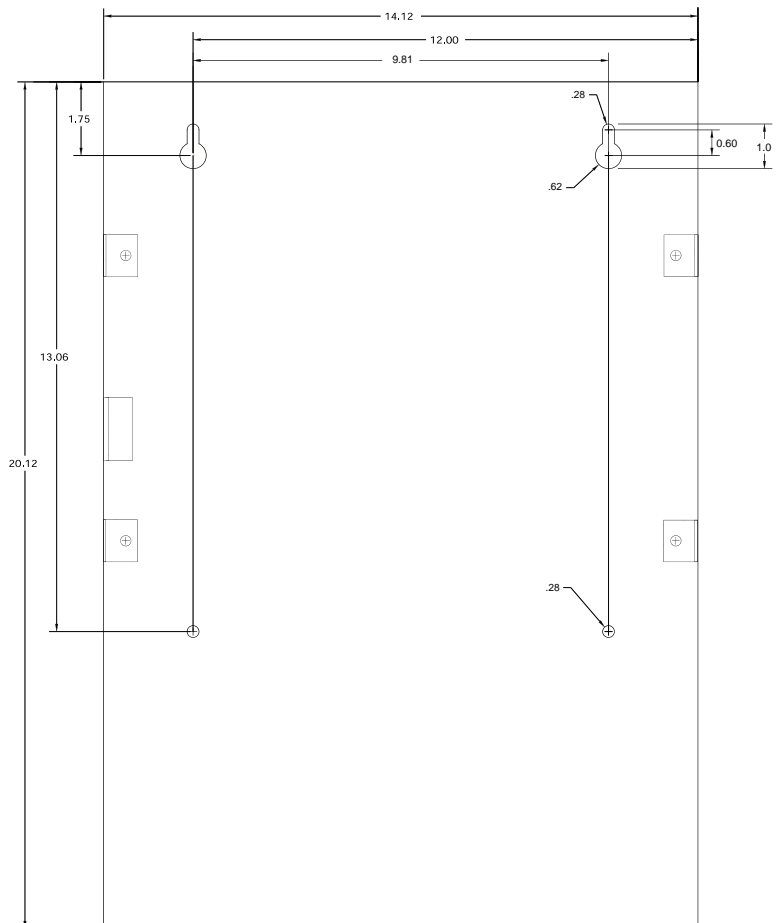
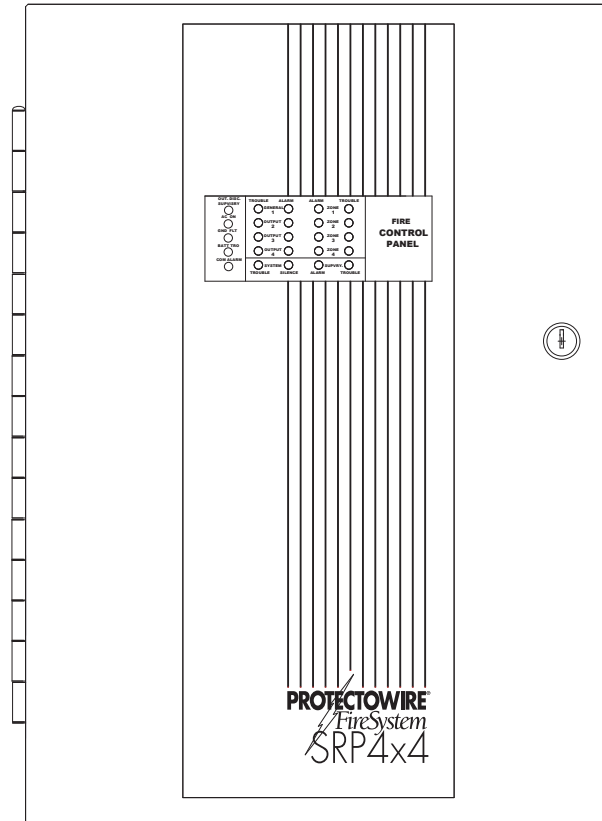

BATTERY CABINET MOUNTING

- The Battery Cabinet should be mounted directly below the SRP-4x4 Panel. The Battery wiring is classified as Non-Power-Limited. Therefore the wiring must be segregated from Power-Limited wiring with a minimum of two cable entry openings and a 1/4" spacing between the two conductors.

- Batteries are connected to the Fire Control Panel by using 16 AWG wire to the supplied PWSC splicing connector (501740) and passed thru closed nipple rigid metal conduit.

- Battery wire leads should be color coded with respect to supplied battery wiring of the panel.

Caution: Always observe polarity when connecting up batteries. Improper connection will cause the battery fuse to blow. See Page 41 for proper Battery Calculation Sizing.

Caution: Batteries contain sulfuric acid which can cause severe burns to the skin and eyes. If contact is made with sulfuric acid, immediately flush skin or eyes with water for 15 minutes and seek immediate medical attention.

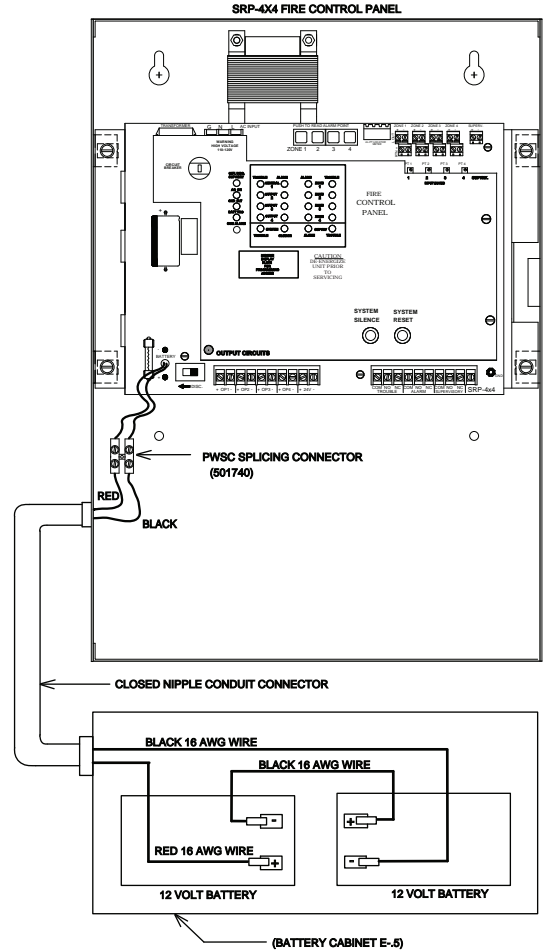

BATTERY CABINET DIMENSIONS

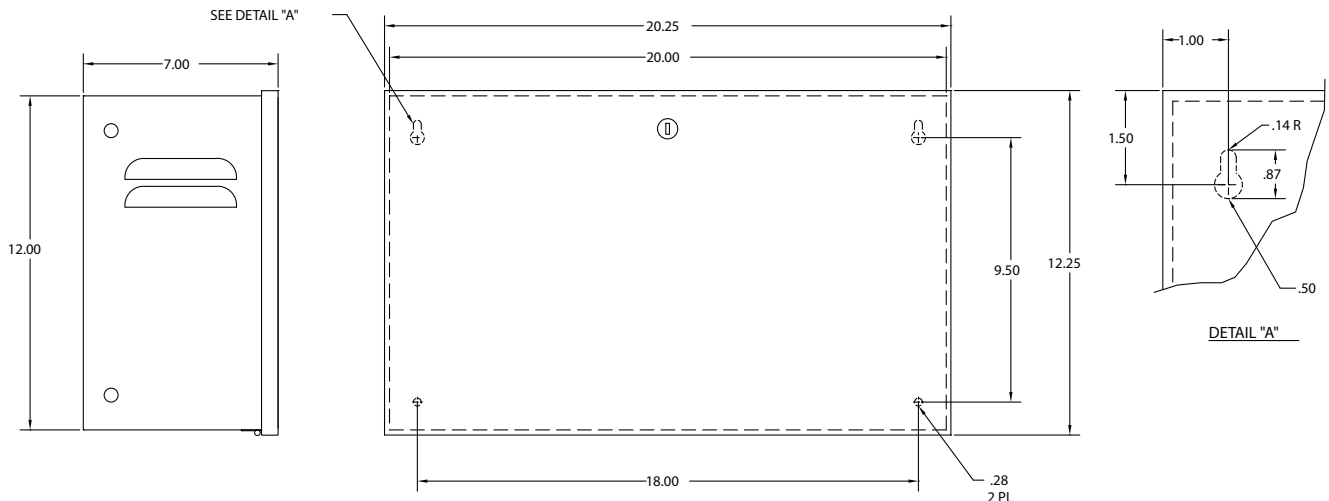

- Battery Cabinet can be purchased in two colors, red (E-.5) or beige (E-.5B)

ALARM NOTIFICATION APPLIANCE CIRCUIT WIRE SIZE ESTIMATOR

To insure that all notification appliance circuits will be supplied with adequate power to operate, it is necessary to use the correct size cable for the distance and current requirements of each circuit. Follow the steps below to calculate the correct wire size for your application. The calculations are based on a maximum line loss (voltage drop) of 1.0 volts.

1. Calculate the required alarm device current.
(Number of Devices) X (Device Current) = Total Alarm Device Current (AMPS)
2. Determine the wire run distance in feet from the panel to the last alarm device.
3. Find the load current (AMPS) on Table 3 that best matches the required alarm device current. If the device current is in between two values, use the higher value.
4. Find the wire run distance to the right of the device current value chosen in step 3 which is greater than your requirement.
5. The gauge at the top of the distance column is what will be required to insure a maximum line loss of less than 1 volt, or 1 ohm max. fully loaded.

EXAMPLE: If the total alarm device load is .680 AMPS; select .750 AMPS. If the measured distance is 400 feet; select 515 feet which is in the 14 AWG column.

**TABLE 1 - COMPATIBLE 24VDC
POLARIZING SIGNALING DEVICES**

DEVICE	MFGR	MODEL	AMPS
HORNS	AMESCO	H24W	0.035
		HW-24	0.035
	WHEELLOCK	MIZ	0.043
	FEDERAL	450	0.25
MOTOR BELLS	AMESCO	MBA-6-24	0.012
		MBA-8-24	0.025
	WHEELLOCK	MB	0.030
STROBE	AMESCO	SLW24W	0.120
		SAD24	0.250
	WHEELLOCK	AHWP	0.100
		ASWP	0.113
	FEDERAL	LP3 SERIES	0.22
HORN/ STROBE	AMESCO	SHW24W	0.088
		SHP24	0.250
	WHEELLOCK	NS4	0.361
STROBE/ BUZZER	FEDERAL	AV1ST	0.39
		AV1	0.98

FOR COMPLETE LIST OF NOTIFICATION APPLIANCE DEVICES AND THEIR CORRESPONDING CURRENT DRAW **SEE APPENDIX A**

**TABLE 2 - COPPER WIRE RESISTANCE
AWG = AMERICAN WIRE GAUGE**

GAUGE (AWG)	OHMS PER 1,000 FT. SINGLE CONDUCTOR
10	1.018
12	1.619
14	2.575
16	4.094
18	6.510

**TABLE 3 - ALARM INDICATING CIRCUIT
WIRE SIZE FOR 24VDC POLARIZING DEVICES**

TOTAL DEVICED LOAD (AMPS)	FEET OF 2 CONDUCTOR WIRE				
	18 AWG	16 AWG	14 AWG	12 AWG	10 AWG
0.060	2560	4070	6470	10290	16370
0.125	1225	1950	3165	4940	7855
0.250	610	975	1550	2470	3925
0.375	405	650	1035	1645	2615
0.500	305	485	765	1235	1960
0.625	245	390	620	985	1570
0.750	200	325	515	820	1305
1.000	150	240	385	615	980
1.250	120	195	310	490	785
1.500	100	160	255	410	650
1.750	85	135	220	350	560
2.000	75	120	190	305	490

NOTE: The maximum alarm indicating circuit resistance is calculated for a line loss of 1 volt divided by the maximum alarm device current.

FIELD WIRING

SUPERVISED INITIATING DEVICE CIRCUITS CLASS A (NFPA STYLE D) / CLASS B (NFPA STYLE B)

Use the following compatible devices approved by The Protectowire Co., Inc.

- UP TO 10,000 FEET OF PROTECTOWIRE (May be placed after last detector)
- UP TO (20) 0.045mA TWO-WIRE HOCHIKI SMOKE DETECTORS

NOTES: Maximum feed cable resistance = 100 OHMS to last smoke detector. Feed cable may consist of any combination of PROTECTOWIRE or copper wire.
 Hochiki Smoke detectors PRO SERIES #SLR-24 (Photoelectric), #SIJ-24 (Ionization)
 Detector Identifier - HD-3 Base Identifier - HB-3. Also, #SLR-24H Photo/Heat Smoke Detector Identifier – HB-3. *Per UL 864 9th edition stipulation has been added that two wire smoke detectors of different models are not to be mixed or matched on a system.*
Note: Power-limited field wiring **must** be isolated from non-power-limited field wiring.
 Use 14 - 18 AWG wire UL Listed for Application.

TYPICAL CLASS B DETECTION
(NFPA STYLES B)

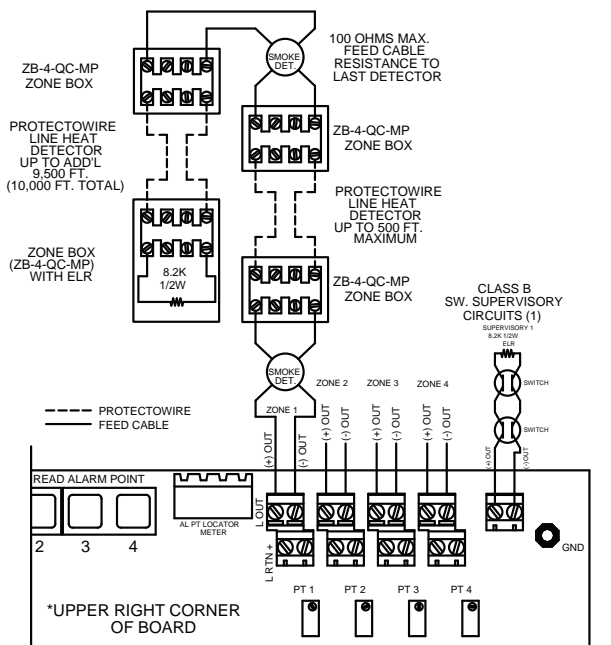

TYPICAL CLASS A DETECTION
(NFPA STYLES D)

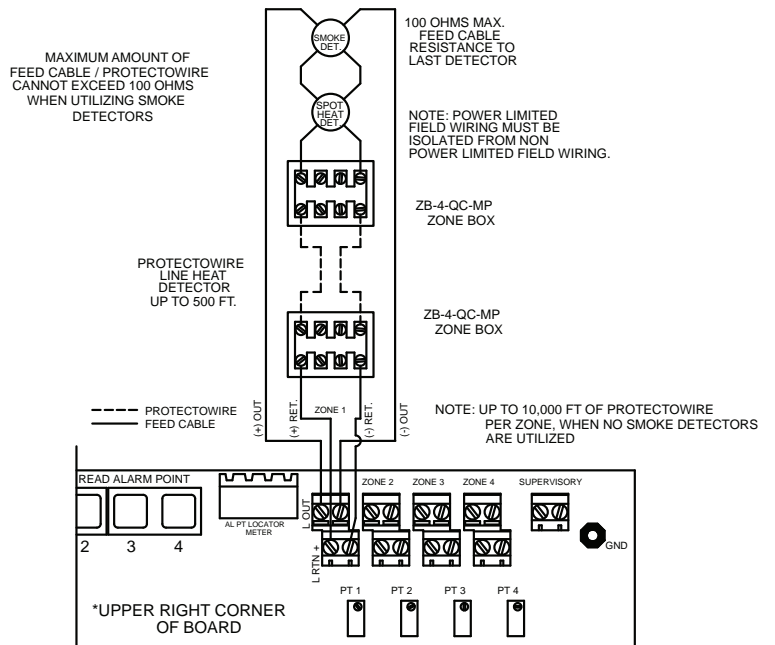

Note:
 The panel is supplied with ELR-8.2K Ohm Resistors on all Initiating circuits. When wiring detection zone in a Class B configuration, these resistors **must** be removed and placed at the end of each detection circuit and mounted in a Protectowire Zone Box (ZB-4-QC-MP). See above illustration.

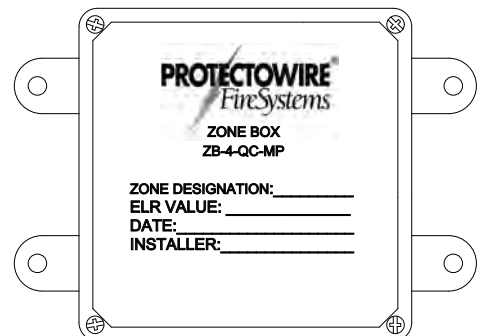

FIELD WIRING

SUPERVISED ALARM NOTIFICATION, SOLENOID RELEASE CIRCUITS & NON-SUPERVISED AUXILIARY 24V USAGE

NOTE: OUTPUT CIRCUIT #1 USED FOR NOTIFICATION PURPOSES ONLY WHILE OUTPUT CIRCUITS #2 thru #4 MAY BE USED FOR EITHER NOTIFICATION AND/OR RELEASING

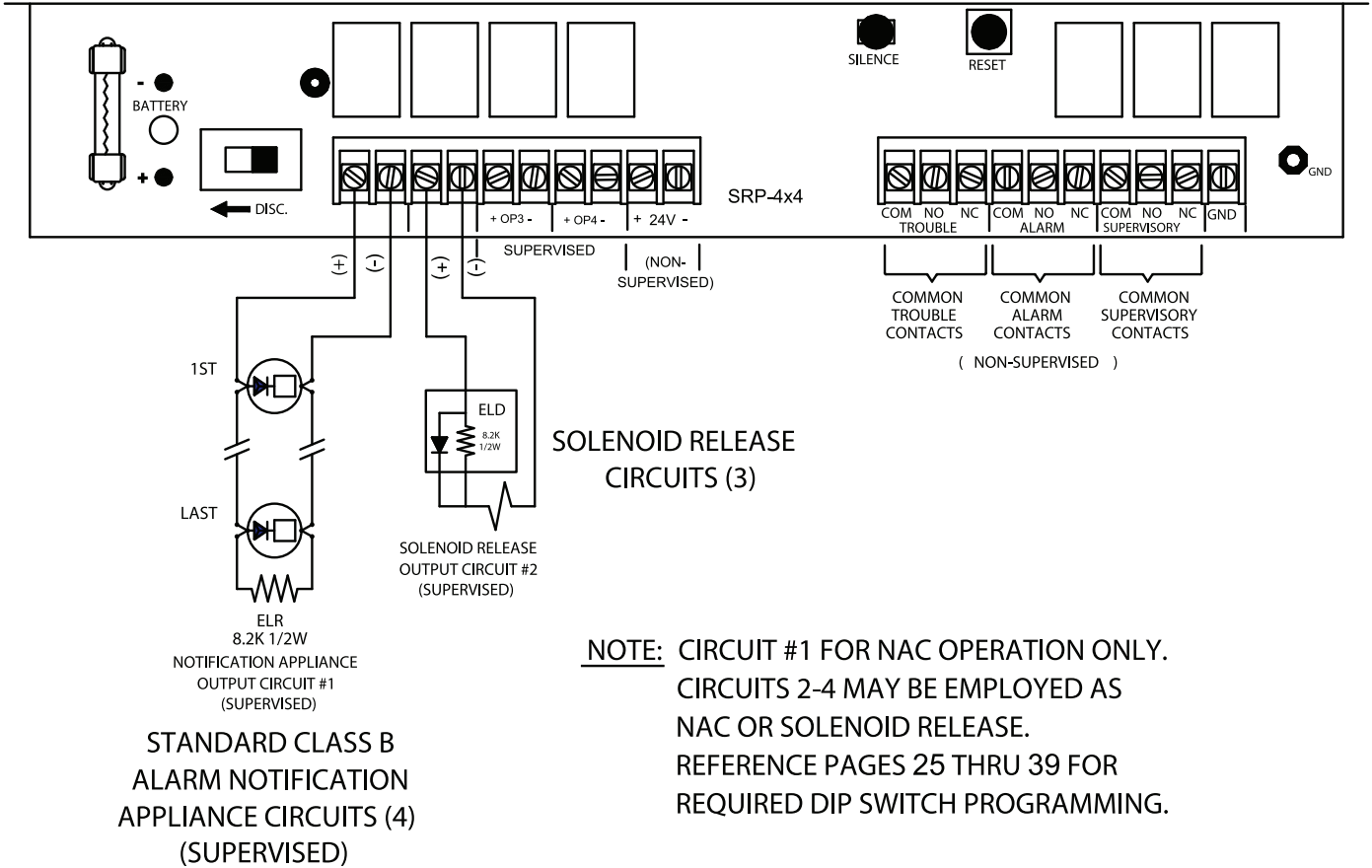

NOTES:

OUTPUT CIRCUITS OP1 THRU OP4 ARE ALL **POWER-LIMITED CIRCUITS** AND MUST BE SEGREGATED FROM NON-POWER-LIMITED CIRCUITS WITH A MINIMUM SPACING OF TWO CABLE ENTRY OPENINGS AND 1/4" SPACING BETWEEN THE TWO CONDUCTOR TYPES. SEE WIRE ROUTING DETAIL FOR LAYOUT.

TO PROVIDE PROPER SUPERVISION OF SOLENOID COILS, THE ELD MUST BE INSTALLED IN THE SAME JUNCTION BOX AS THE SOLENOID.

AUXILIARY 24 V OUTPUT IS POWER-LIMITED, WITH A MAXIMUM CURRENT DRAW OF 100mA. IT IS AN UN-SUPERVISED CIRCUIT, THEREFORE IT CAN ONLY BE USED FOR THREE PURPOSES PER **UL 864** REQUIREMENTS.

USE 10-14 AWG WIRE, UL LISTED FOR APPLICATION.

PDM-1000-4

PROTECTOWIRE ALARM POINT LOCATION METER

DESCRIPTION:

The PDM-1000-4 PROTECTOWIRE Digital Alarm Point Location Meter is designed to help locate a heat actuated point on a PROTECTOWIRE line heat detector circuit. This meter identifies the distance in feet or meters (preset at the factory) along the detector from the start of the run to the actuated point.

Note: The PDM-1000-4 is calibrated at the factory and only requires adjustment to compensate for field cable resistance at the time of installation.

OPERATION:

When an alarm signal is received at the main control panel, depress the meter switch (see illustration below) of the zone in alarm. The meter will then display the distance to the actuated portion of the PROTECTOWIRE line heat detector circuit.

CALIBRATION:

The copper feed wire between the control panel and the zone (junction) box at the start of the PROTECTOWIRE run has an inherent resistance. This resistance although small compared to that of the PROTECTOWIRE, will introduce an error in the digital meter reading. The longer the feed wire, the greater the error. Adjust the meter per the following procedure to compensate for field wiring resistance.

1. Disconnect all alarm and/or releasing devices connected to the control panel and apply power to the system before proceeding.
2. Connect a jumper wire across the detection circuit at the beginning of the PROTECTOWIRE run (at the zone box). **Caution:** This will trip the detection circuit into an alarm condition.
3. At the control panel press the meter read switch for the appropriate zone in alarm. The meter will display the feed cable error.
4. To cancel out (zero) this value, adjust the corresponding PT# potentiometer on the main panel for the zone in alarm by using a small screwdriver to turn the potentiometer until the meter reads zero (see below).
Note: the positive (+) and negative (-) indicator will fluctuate when zeroed.
5. Repeat this procedure for all other zones containing PROTECTOWIRE line heat detector.

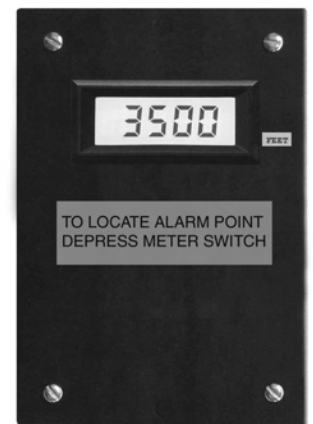

Note:

The PROTECTOWIRE digital meter is designed for reading lengths of PROTECTOWIRE line heat detector cable installed at an ambient temperature of 70° F. Since the inner conductors of PROTECTOWIRE consists of two steel wires, the inherent cable resistance is subject to change proportionally to temperature. For each 10° F change in temperature a 1% change in total measure cable length can be expected. Using #14 AWG or larger copper feed wire in detection circuits that have PROTECTOWIRE will minimize meter reading error.

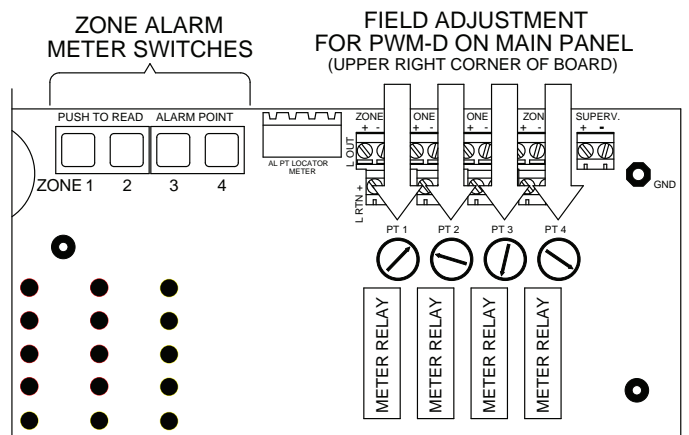

RB-4

AUXILIARY RELAY MODULE

Description - Auxiliary signaling relays are often needed to provide an interface to other systems for annunciation and/or electrical shutdown. The RB-4 Relay Module provides 4 individually zone activated sets of Form “C” contacts in one module.

Operation - The RB-4 relays are normally de-energized. Each relay (1 – 4) is activated by an alarm of its corresponding input circuit (1 – 4). Indicators L1 through L4 (Red) illuminate when the corresponding relay is activated.

Form “C” Contacts

Electrical

DC Contact Rating - 1 AMP @ 24VDC (Resistive)
 Contact Configuration (4) - SPDT
 Coil Rating each (4) - 0.013 AMPS @ 24VDC
 Terminal Wire Capacity - 18-14 AWG Solid/Braid
 Indicator - Red LED

RB-4

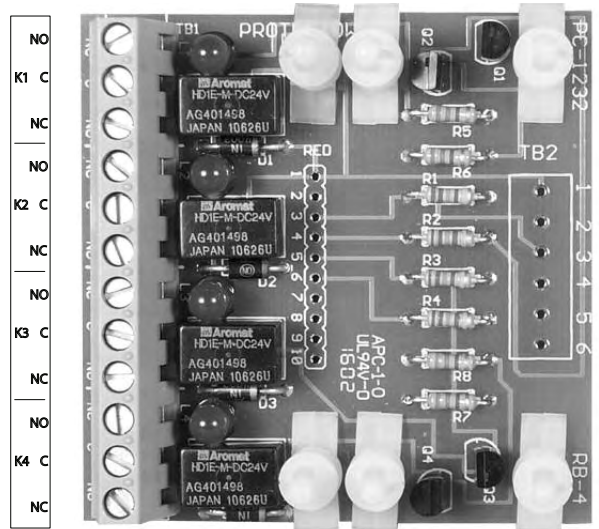

Mounting Diagram

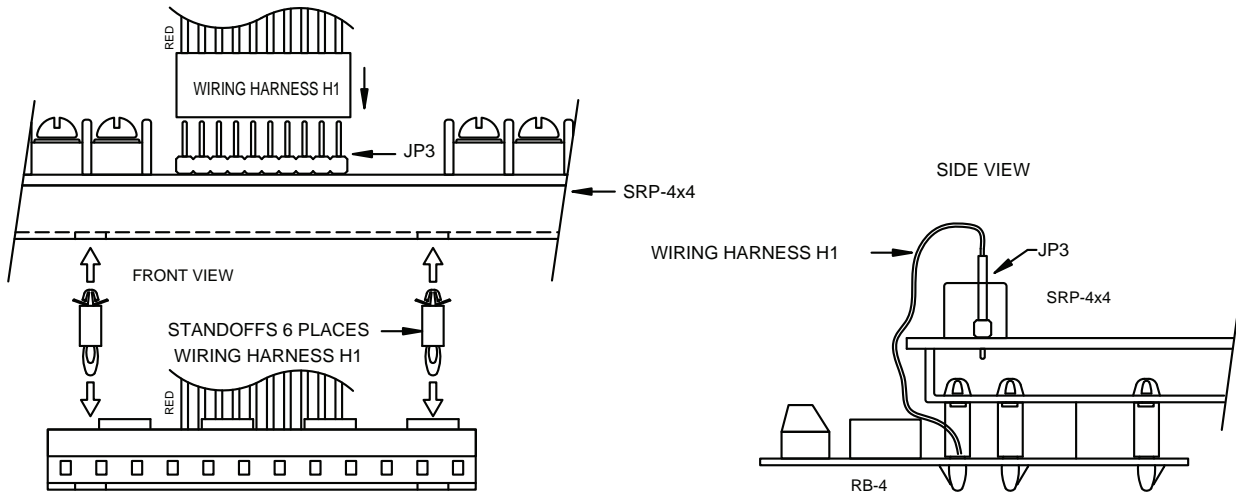

CLASS "A" ALARM NOTIFICATION APPLIANCE CIRCUIT ADAPTER

Description: The AM-91-2 Alarm Notification Appliance Circuit Adapter Module converts the two Class B system Alarm Notification Appliance Circuits from the Main Board to Class A type circuits. This provides four wire alarm notification appliance circuits in lieu of the standard 2 wire circuits.

Operation: The two wire Class B circuits are wired into the module input terminals (TB1). The AM-91-2 then conditions and converts the circuits to four wire Class A alarm notification appliance circuits. This Alarm notification appliance output circuit is fully supervised with the reverse polarity current flow. A short or open in the field wiring is detected by the system controls. Once an alarm is initiated the circuit immediately reverses polarity and the 24V FWR power is supplied to the alarm notification appliance devices. If a single break occurs in the circuit all devices will still be supplied power in an alarm state due to the nature of a Class A wiring configuration.

Voltage standby Current	24V regulated Full wave rectified (FWR) with battery 1 AMPS per circuit 2.1 AMPS maximum combined.
Maximum 2 conductor copper feed cable resistance may not exceed 1 OHM (see below)	
#10 AWG	Maximum of 500' (feet) Reference DS-9066
#12 AWG	Maximum of 300' (feet) Reference DS-9066
#14 AWG	Maximum of 200' (feet) Reference DS-9066

AM-91-2 Class A Alarm Notification Appliance
Circuit Adapter Module

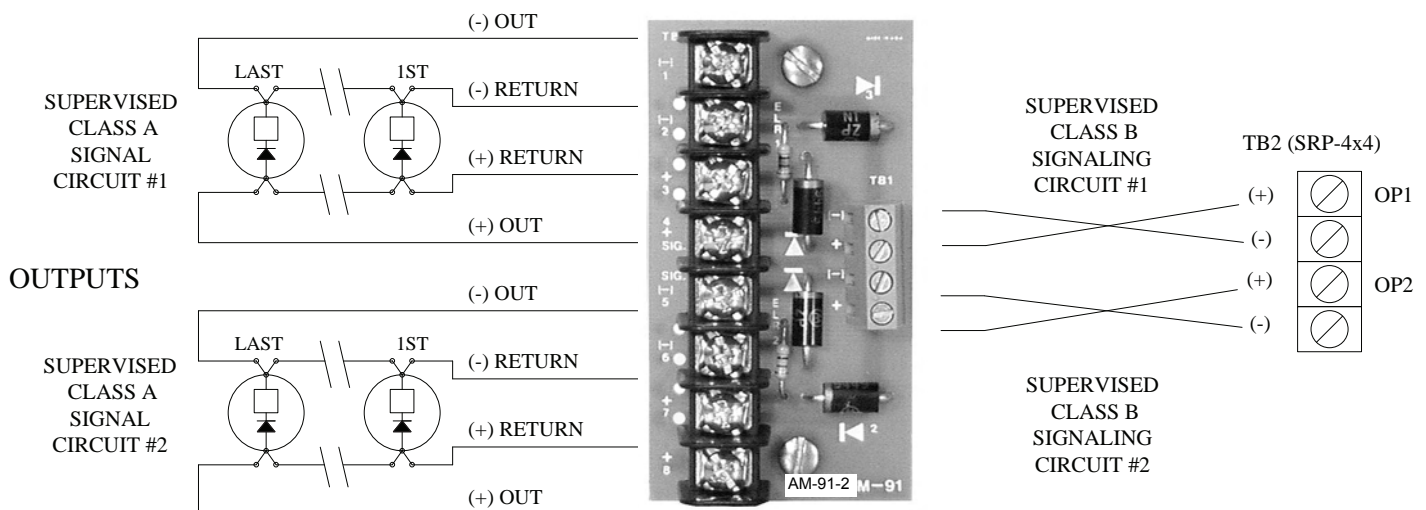

Note: Polarity of Notification Appliance Circuits shown in Alarm Condition

SRP 4x4 STANDARD RELEASE PANEL

INSTALLATION, TESTING & MAINTENANCE

Installation & System Power Up.

1. Carefully unpack system and inspect for any visual damage from shipping. Bench testing of panel for proper operation prior to installation is recommended.
2. Mount the system in a clean, easily accessible, stable area with four (4) 1/4” screws. The system enclosure should be mounted to allow clear visibility of the systems control indicators and easy access to the systems control switches.
3. Wire the system according to this manual. Wiring should be in accordance with applicable National and/or Local Electrical and Fire Alarm Codes. **Warning:** Conduit entry through the electrical enclosure must be made using knockouts provided. When making conduit entries, take preventative measures to ensure metal drill filings and debris does not enter the components of the system. All conduit entries should be sealed to avoid water entering from the conduit system into the system enclosure. ***Failure to comply with the above will void the factory warranty.***

Special Note: All supervised circuits are conditioned at the factory with an end-of-line resistor (ELR-8.2K) or dummy load resistor across the circuit field terminals. The end-of-line resistors must be removed when field wiring is connected to the circuit terminations. Class B supervised circuits require the ELR to be connected at or after the last device on the circuit. Class A supervised circuits do not require an ELR. Output Circuits are conditioned with a dummy resistor across the field connections when shipped from factory. The resistor must be removed when field wiring is connected at the field terminals. Refer to field wiring diagram for proper selection and installation of end-of-line devices.
4. Slide Output Disconnect Switch to the left (disconnect) position to prevent accidental activation of output circuits 2 - 4. Note that Output 1 is NOT disconnected through this switch. Disconnect Output 1 by removing field wiring.
5. Connect AC power according to the systems rating as identified on the model ID tag mounted on the inside of the enclosure door.
 - a) Load connection AC INPUT TB3 Terminal “L”
 - b) Neutral connection AC INPUT TB3 Terminal “N”
 - c) Ground connection AC INPUT TB3 Terminal “G”
6. When applying power to systems with output circuits disconnected; the system will be in a trouble condition due to the disconnection of the output circuits in step 4. Silence the system by pressing the “System Silence” button.
7. Disconnect dummy battery load 2.2K resistor from the system battery connectors and connect standby batteries. Allow 48 hours for batteries to charge to full capacity.
8. Verify that no trouble indicators are illuminated except under the following conditions. The disconnect switch is in the left (disconnect) position and the “OUT. DISC. SUPVISRY” indicator is illuminated. The batteries connected to the system are not pre-charged and the “BATT TRO” indicator is illuminated. If any other trouble lights are illuminated determine the problem with those circuits using the troubleshooting guide in this manual and repair them before continuing.
9. Only after the system has been cleared from any erroneous alarm or trouble signals, bring the disconnected output circuits “on line” by sliding the Output Disconnect Switch to the right (connected) position. The “AC ON” indicator should be the only system indicator illuminated.
10. Test the system per the “Test and Maintenance” procedure in this manual.

SRP 4x4 STANDARD RELEASE PANEL

INSTALLATION, TESTING & MAINTENANCE

Testing and Maintenance

Quarterly testing is advised to help insure system controls are functioning properly. Testing should be performed by competent personnel having jurisdiction over the protective signaling system. The following instructions should be observed in conjunction with the System Operational Outline contained in this manual when testing this equipment.

1. Notify the applicable local fire department and/or alarm receiving station.
2. Inform all personnel in the facility that testing is in progress, start of testing to finish.
3. Disconnect any and all auxiliary alarm devices (solenoids, system shutdowns, etc.).
4. ALARM TEST, slide Output Circuit Disconnect switch to left (disconnect) position to prevent accidental activation of output circuits 2, 3, & 4. Place a jumper across each detection/initiating circuits field terminations.
5. Press the "System Reset" button located on the control panel to return to standby condition.
6. SUPERVISION TEST, Open supervised circuits (Detection, Switch Supervisory, Alarm Notification Appliance Circuits, Solenoid, Waterflow Detection, etc.) by removing one wire lead from the field terminal for each individual circuit one at a time. Replace each wire before moving on to the next circuit. Momentarily short each output circuit with jumper wire to verify trouble condition. Remove short prior to testing next circuit.

Testing Note:

The following LED indications will occur in addition to the system ground fault trouble when the respective circuit is connected to earth ground with a resistance up to 2.2K ohms.

- a) The "SYSTEM TROUBLE" indicator will illuminate if the positive or negative leg of a detection circuit is connected to the earth ground.
- b) The Output Circuits respective "TROUBLE" indicator along with the "SYSTEM TROUBLE" indicator will illuminate if the positive leg of the circuit is connected to earth ground. Only the "SYSTEM TROUBLE" indicator will illuminate if the negative leg of the circuit is connected to earth ground.
- c) The "SYSTEM TROUBLE" indicator will illuminate if the positive or negative leg of the Switch Supervisory Circuit is connected to earth ground.

These indications are an adverse effect caused by ground faults but can prove useful in identifying the location of a ground fault when they occur.

WARNING

**FATAL ELECTRIC SHOCK AND EQUIPMENT DAMAGE
MAY RESULT FROM FAILURE TO REMOVE AND LOCK OUT ALL
POWER PRIOR TO SERVICING SYSTEM**

SRP 4x4 STANDARD RELEASE PANEL

INSTALLATION, TESTING & MAINTENANCE

Operational Outline:

1. Normal Standby Condition

- a) "AC ON" Indicator (Green) illuminated.

2. Power Supervision

AC power source failure:

- a) "AC ON" Indicator (Green) OFF.
- b) System trouble buzzer ON - Press "SYSTEM SILENCE" button to silence.
- c) "SYSTEM TROUBLE" Indicator (Yellow) ON.
- d) Restore AC power to resume standby condition.

DC power source failure:

- a) "SYSTEM TROUBLE" Indicator (Yellow) ON.
- b) "BATT TRO" Indicator (Yellow) ON.
- c) System trouble buzzer ON - Press "SYSTEM SILENCE" button to silence.
- d) Restore DC power to resume standby condition.

3. Initiating Device Circuits (Input)

Short in detection loop/device = Alarm Condition:

- a) "ZONE ALARM" Indicator (Red) ON.
- b) Respective "OUTPUT ALARM" Indicator (Red) ON (Reflects panel operation logic).
- c) Respective Output Circuits activated - Press "SYSTEM SILENCE" button to silence, "SYSTEM SILENCE" indicator (Yellow) ON.
- d) Restore Detection Circuit or Initiating Device. Press "SYSTEM RESET" button to return to standby condition.

Open in Detection Loop - Zone Trouble/System Trouble:

- a) "SYSTEM TROUBLE" Indicator (Yellow) ON.
- b) "ZONE TROUBLE" Indicator (Yellow) ON.
- c) System trouble buzzer ON - Press "SYSTEM SILENCE" button to silence.
- d) Clear Detection Circuit to return to standby condition.

4. Output Circuits

Short in Output Circuit loop:

- a) "SYSTEM TROUBLE" Indicator (Yellow) ON.
- b) Respective "OUTPUT TROUBLE" Indicator (Yellow) ON.
- c) System trouble buzzer ON - Press "SYSTEM SILENCE" button to silence.
- d) Clear (repair) short in circuit to return to standby condition.

Open in Circuit loop:

- a) "SYSTEM TROUBLE" Indicator (Yellow) ON.
- b) Respective "OUTPUT TROUBLE" Indicator (Yellow) ON.
- c) System trouble buzzer ON - Press "SYSTEM SILENCE" button to silence.
- d) Clear (repair) short in circuit to return to standby condition.

5. Switch Supervisory Zone

Short in Switch Supervisory Circuit - Supervisory Alarm:

- a) "SUPERVISORY ALARM" Indicator (Yellow) ON.
- b) System trouble buzzer ON - Press "SYSTEM SILENCE" button to silence.
- c) Restore Supervisory Circuit or initiating device. Press "SYSTEM RESET" button to return to standby condition.

SRP 4x4 STANDARD RELEASE PANEL

INSTALLATION, TESTING & MAINTENANCE

Operational Outline Continued:

5. Switch Supervisory Zone Continued

Open in Switch Supervisory Circuit - Supervisory Trouble/System Trouble:

- a) "SYSTEM TROUBLE" Indicator (Yellow) ON.
- b) "SUPERVISORY TROUBLE" Indicator (Yellow) ON.
- c) System trouble buzzer ON - Press "SYSTEM SILENCE" button to silence.
- d) Repair Open to return to standby condition.

6. Ground Fault Detection Circuit

When undesirable current flows to ground from the system DC power supply, either positive or negative:

- a) "SYSTEM TROUBLE" Indicator (Yellow) ON.
- b) "GND FLT" Indicator (Yellow) ON.
- c) System trouble buzzer ON - Press "SYSTEM SILENCE" button to silence.
- d) Repair Ground Fault and allow 5 seconds for system to restore to standby condition.

7. Output Disconnect Supervisory - Slide Output disconnect switch to the left position.

- a) "OUT. DISC. SUPVISRY" Indicator (Yellow) ON.
- b) System trouble buzzer ON - Press "SYSTEM SILENCE" button to silence.
- c) Restore switch to normal right position to clear.

SRP 4x4 STANDARD RELEASE PANEL

TROUBLESHOOTING

BASIC TROUBLESHOOTING GUIDE FOR THE SRP 4x4 STANDARD RELEASE PANEL				
	INDICATOR STATUS	FAULT CONDITION	COURSE OF ACTION	ALTERNATE ACTION
Primary	"AC ON" Indicator OUT "SYS. TRO." Indicator ON Trouble buzzer ON	AC Power source failure	Check AC power source connections & voltage. Reset Circuit breaker CB1.	Check secondary voltage from transformer across 1st two pins of JP1 = 30V approx.
Standby Power	"AC ON" Indicator ON "SYS. TRO." Indicator ON "BATT. TRO" Indicator ON Trouble Buzzer ON	Backup Power source failure Batteries disconnected or overcharged	Check battery connections Check battery fuse F1	Check battery voltage with charger connected. Voltage should read between 26 - 28 volts. Replace batteries if needed.
	"AC ON" Indicator ON "SYS. TRO." Indicator ON "BATT. TRO" Indicator ON Trouble Buzzer ON	Backup Power source failure Batteries undercharged or drained below acceptable voltage level.	Check the battery voltage and be sure to allow at least 48 hours for charging of new or drained battery sets. If batteries do not charge replace them.	If condition still exists, consult factory.
Output Circuits	"AC ON" Indicator ON "SYS. TRO." Indicator ON Respective "OUTPUT" Trouble Indicator ON Trouble Buzzer ON	Output Circuit fault. A short or an open exists in the Output Circuit field wiring.	Remove the Output Circuit field wiring from the field terminals and replace with an end-of-line resistor ELR-8.2K ohm. If the condition clears the fault is in the field wiring. Find and replace short, or repair open.	If condition still exists, consult factory.
Ground Fault	"AC ON" Indicator ON "SYS. TRO." Indicator ON "GND FLT" Indicator ON Trouble Buzzer ON	A ground fault exists. Either a Positive or Negative connection exists to the earth ground in the system or its field wiring.	All field wiring must be tagged and removed from the field terminals until the condition clears or all wiring has been isolated. If condition clears after removing a field wire, the fault/s exist in that wire. Repair fault and reconnect all field wiring.	If after all field wiring is isolated from the panel the condition still exists, consult factory.
Detection Circuits	"AC ON" Indicator ON "SYS. TRO." Indicator ON "ZONE TRO." Indicator ON Trouble Buzzer ON <i>(includes detection, waterflow, and switch supervisory zones)</i>	Open in zone circuit field wiring.	<p>Class B - Remove the Zone Circuit field wiring from the field terminals and replace with an end-of-line resistor ELR-8.2K ohm across the (+) and (-) out terminals.</p> <p>Class A - Place jumpers across the field terminals in a Class A configuration. If the condition clears the fault is in the field wiring. Find and repair open.</p>	If the circuit does not clear when conditioned as stated previously, consult the factory.

SRP 4x4 STANDARD RELEASE PANEL

TROUBLESHOOTING CONTINUED

BASIC TROUBLESHOOTING GUIDE FOR THE SRP 4x4 STANDARD RELEASE PANEL				
	INDICATOR STATUS	FAULT CONDITION	COURSE OF ACTION	ALTERNATE ACTION
Detection Circuits	"AC ON" Indicator ON "SYS. ALARM" Indicator ON Zone "ALARM" Indicator ON	Short in zone circuit field wiring or initiating device in alarm, i.e. Smoke detector, Linear heat detector, etc.	Class B - Remove the zone circuit field wiring from the field terminals and replace with an end-of-line resistor ELR-8.2K ohm across the (+) and (-) out terminals. Class A - Place jumpers across the field terminals in a Class A configuration. Depress the "SYSTEM RESET" button. If the condition clears fault is in the field wiring. Find and repair short of initiating device.	If the circuit does not clear when conditioned as stated previously, consult the factory.

WIRING DIAGRAM PROGRAM #1

SINGLE RELEASE, THREE ALARM ZONES WITH ONE WATERFLOW ZONE AND SUPERVISORY ZONE WITH SYSTEM TROUBLE/ SUPERVISORY BELL CIRCUIT

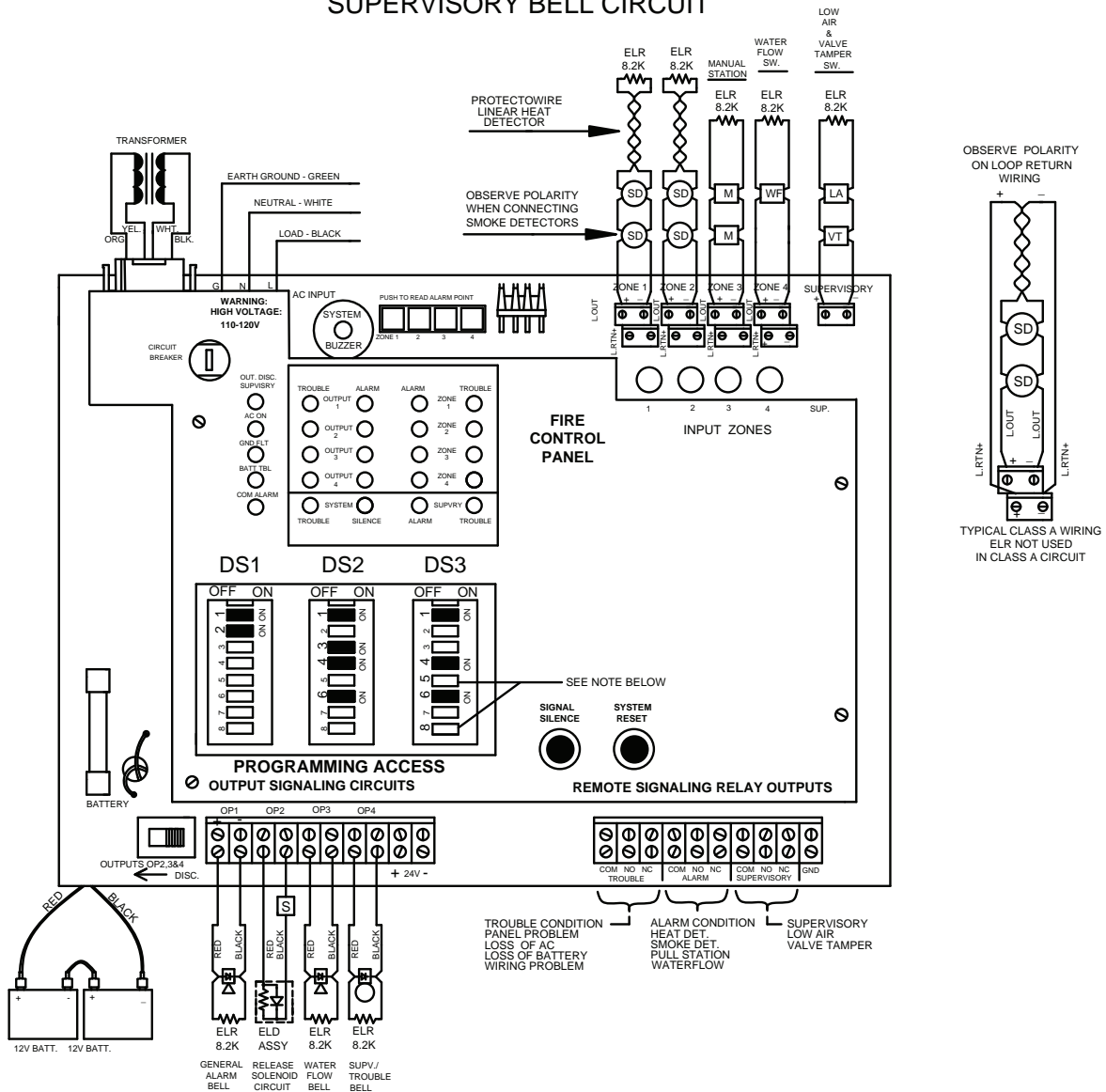

Description: Single release - three zone

Inputs: (2) IDC zones, (1) manual pull zone, (1) waterflow zone, (1) supervisory zone.

Outputs: (1) general alarm bell, (1) solenoid release, (1) waterflow bell, (1) supervisory bell.

Operation: Activation of either IDC zone or manual pull zone will operate the release circuit and general alarm output circuit.

Activation of the waterflow zone will operate the waterflow bell output circuit.

Activation of the supervisory zone will operate the suprvy./trouble bell #4 output circuit.

A trouble condition (low/disc. battery, wire problem, etc.) will operate the supv./trouble bell.

When either Zone 1, 2 or 3 is in alarm - Output #1 (general alarm) and Output #2 (solenoid release) will operate.

When Zone 4 is in alarm - Output #3 will operate the waterflow bell circuit.

When the supervisory zone is activated - Output #4 will operate supervisory bell only.

Note: DS3 SW5 & 8 placed to the "ON" position for Output #4 to activate on either supervisory or trouble signals. Supervisory bell must provide a distinct sound which is different than alarm bells.

revised 3-31-2008

WIRING DIAGRAM PROGRAM #2

SINGLE RELEASE, TWO ALARM ZONES (CROSS-ZONED), ONE MANUAL PULL STATION
ZONE, ONE WATERFLOW ZONE AND ONE SUPERVISORY ZONE
WITH SYSTEM TROUBLE/SUPERVISORY OUTPUT BELL CIRCUIT

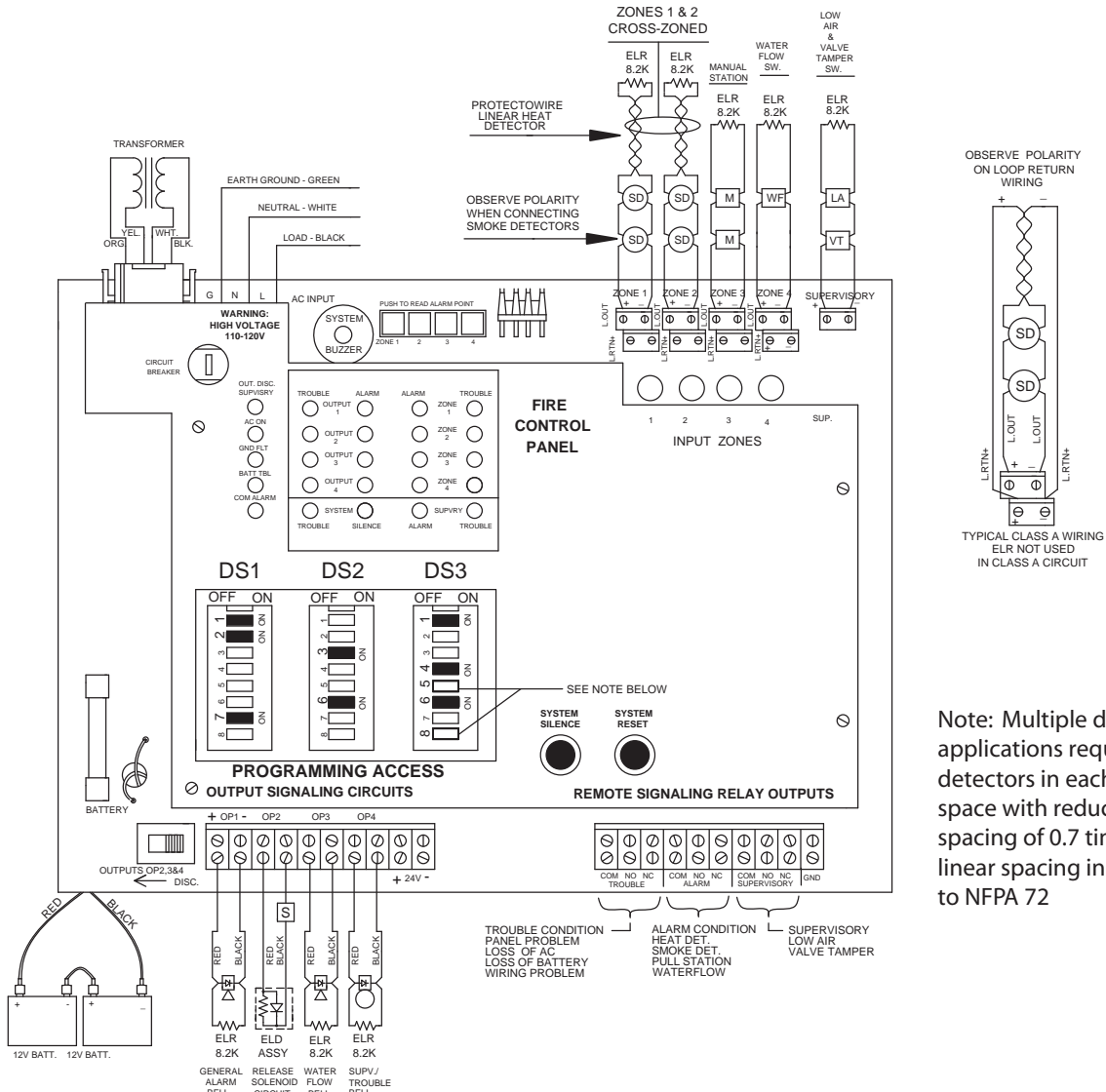

Description: Single release, cross-zoned with manual station override.

Inputs: (2) IDC zones (cross-zoned), (1) manual pull zone, (1) waterflow zone, (1) supervisory zone

Outputs: (1) general alarm bell ckt, (1) solenoid release, (1) waterflow bell, (1) supervisory/trouble bell ckt.

Operation: Activation of both IDC zones at the same time, or activation of the manual pull zone will operate the release output and the general alarm output circuit.

Activation of one IDC zone will operate the general alarm output.

Activation of the waterflow zone will operate the waterflow bell output circuit.

Activation of the supervisory zone will operate the supervisory/trouble bell output circuit.

A trouble condition (low/disc. battery, wire problem, etc.) will operate the supv./tro. bell.

When Zone 1, 2 or 3 is in alarm - Output #1 will operate (general alarm bell).

When Zone 3 is in alarm - Outputs #2 (solenoid release) and #1 (general alarm) will operate.

When Zones 1 and 2 are in alarm at the same time - Output #2 will operate (solenoid release).

When Zone 4 is in alarm - Output #3 will operate the waterflow bell circuit.

When the supervisory zone is activated - Output #4 will operate the supervisory only bell.

Note: DS3, SW5 & 8 placed to the "ON" position for Output #4 to activate on either supervisory or trouble signals. Supervisory bell must provide a distinct sound which is different than Alarm bell.

revised 3-31-2008

WIRING DIAGRAM PROGRAM #3

DUAL COMBINED RELEASE, TWO ALARM ZONES, ONE MANUAL STATION ZONE,
ONE WATERFLOW ZONE, AND ONE SUPERVISORY ZONE
WITH SYSTEM TROUBLE/SUPERVISORY OUTPUT BELL CIRCUIT

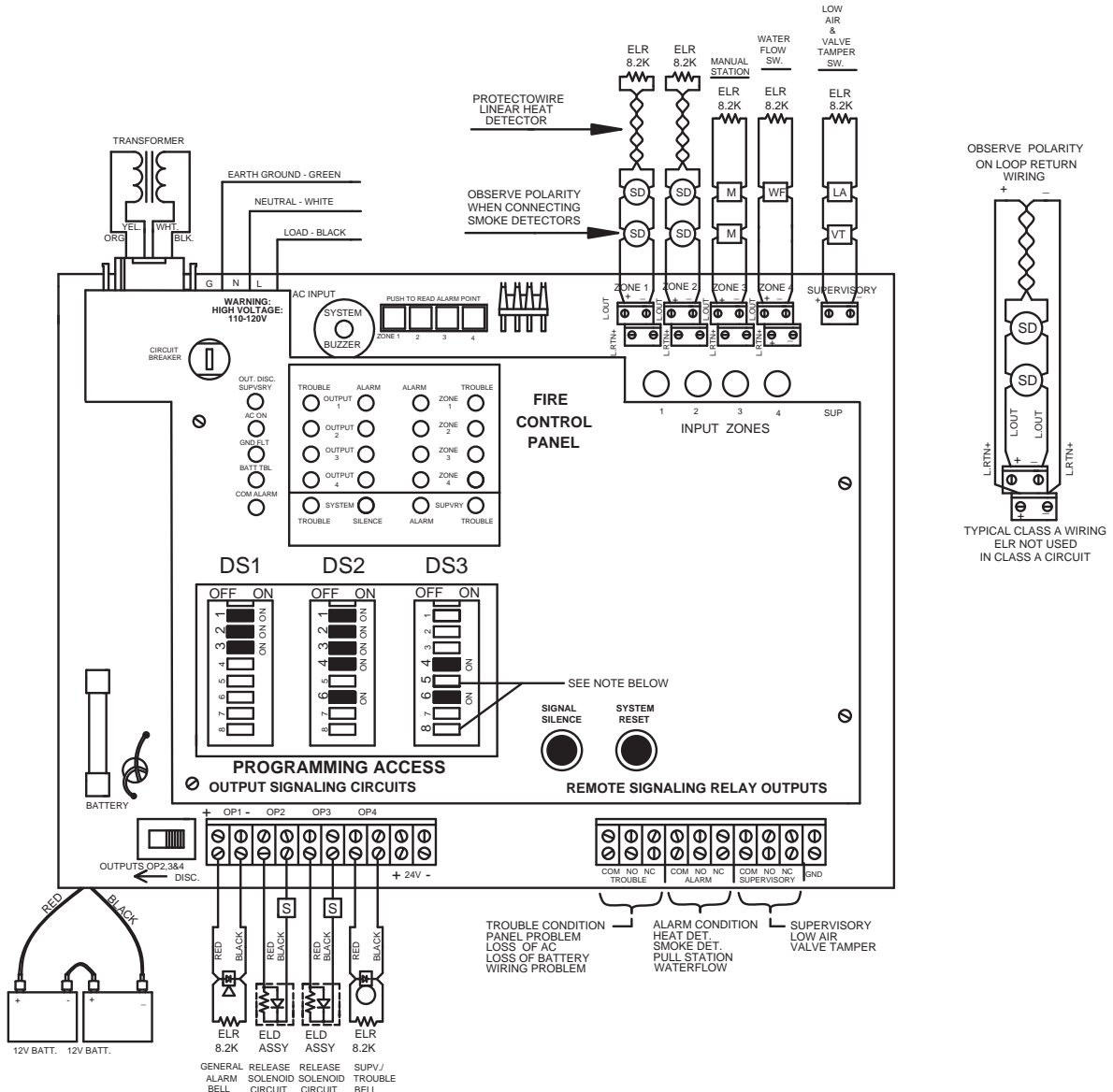

Description: Dual combined release - three zones

Inputs: (2) IDC zones, (1) manual pull zone, (1) waterflow zone, (1) supervisory zone

Outputs: (1) general alarm bell ckt, (2) solenoid release ckts, (1) supervisory trouble bell ckt.

Operation: Activation of either IDC zone or manual pull zone will operate both solenoid release outputs and the general alarm output bell.

Activation of the waterflow zone will operate the general alarm bell.

Activation of the supervisory zone will operate the supervisory/trouble bell output circuit.

A trouble condition (low/disc. battery, wire problem etc.) will operate the supv./tro. bell.

When either Zone 1, 2 or 3 is in alarm - Output #1 (general alarm) and outputs #2 and #3 (solenoid release) will operate.

When Zone 4 is in alarm - Output #1 (general alarm) will operate.

When the supervisory zone is activated - Output #4 will operate supervisory only bell.

Note: DS3, SW5 & 8 placed to the "ON" position for Output #4 to activate on either supervisory or trouble signals. Supervisory bell must provide a distinct sound which is different than alarm bell.

revised 3-31-2008

WIRING DIAGRAM PROGRAM #4

DUAL SPLIT RELEASE, TWO ALARM (IDC) ZONES,
ONE WATERFLOW ZONE, AND TWO SUPERVISORY ZONES WITH SYSTEM
TROUBLE/SUPERVISORY OUTPUT BELL CIRCUIT

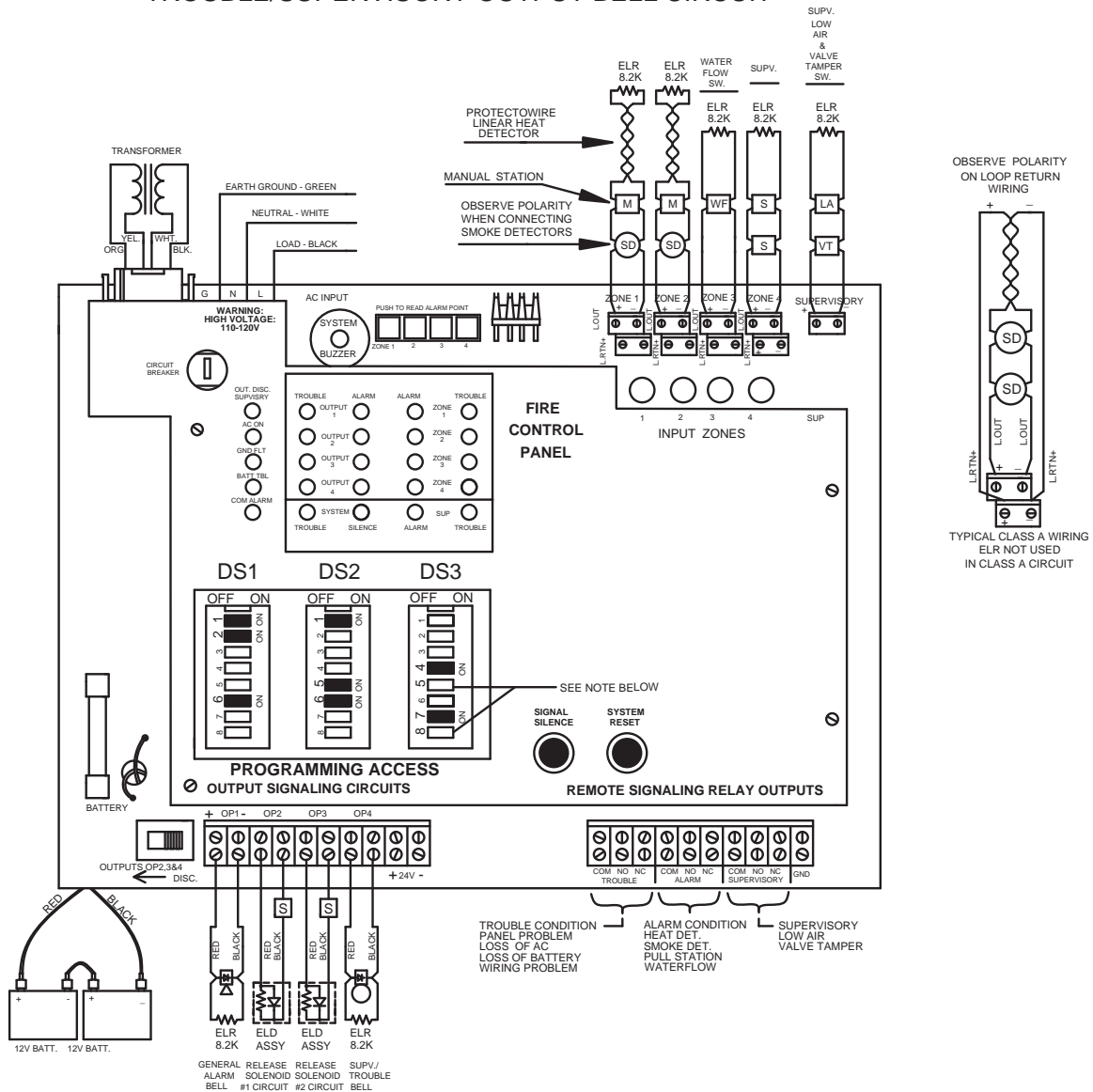

Description: Dual split release - two zones

Inputs: (2) IDC zones, (1) waterflow zone, (2) supervisory zones

Outputs: (1) general alarm bell ckt, (2) solenoid release ckt, (1) supervisory/trouble bell ckt.

Operation: Activation of IDC Zone #1 will operate solenoid release #1 (Output #2) and the general alarm bell.

Activation of IDC Zone #2 will operate solenoid release #2 (Output #3) and the general alarm bell.

Activation of the waterflow zone will operate the general alarm bell.

Activation of either supervisory zone will operate the supervisory/trouble bell.

A trouble condition (low/disc. battery, wire problem etc.) will operate the supv./tro. bell.

When Zone 1 is in alarm - Output #1 (general alarm) and Output #2 (solenoid #1) will operate.

When Zone 2 is in alarm - Output #1 (general alarm) and Output #3 (solenoid #2) will operate.

When Zone 3 is in alarm (waterflow) - Output #1 (general alarm) will operate.

When either Zone 4 or the supervisory zone are activated - Output #4 (supv.) will operate.

Note: DS3, SW5 & 8 placed to the "ON" position for Output #4 to activate on either supervisory or trouble signals. Supervisory bell must provide a distinct sound which is different than alarm bell.

revised 3-31-2008

WIRING DIAGRAM PROGRAM #5

SINGLE RELEASE WITH TROUBLE BELL - TWO ALARM ZONES, 1 MANUAL PULL STATION ZONE, ONE WATERFLOW ZONE, AND ONE SUPERVISORY ZONE

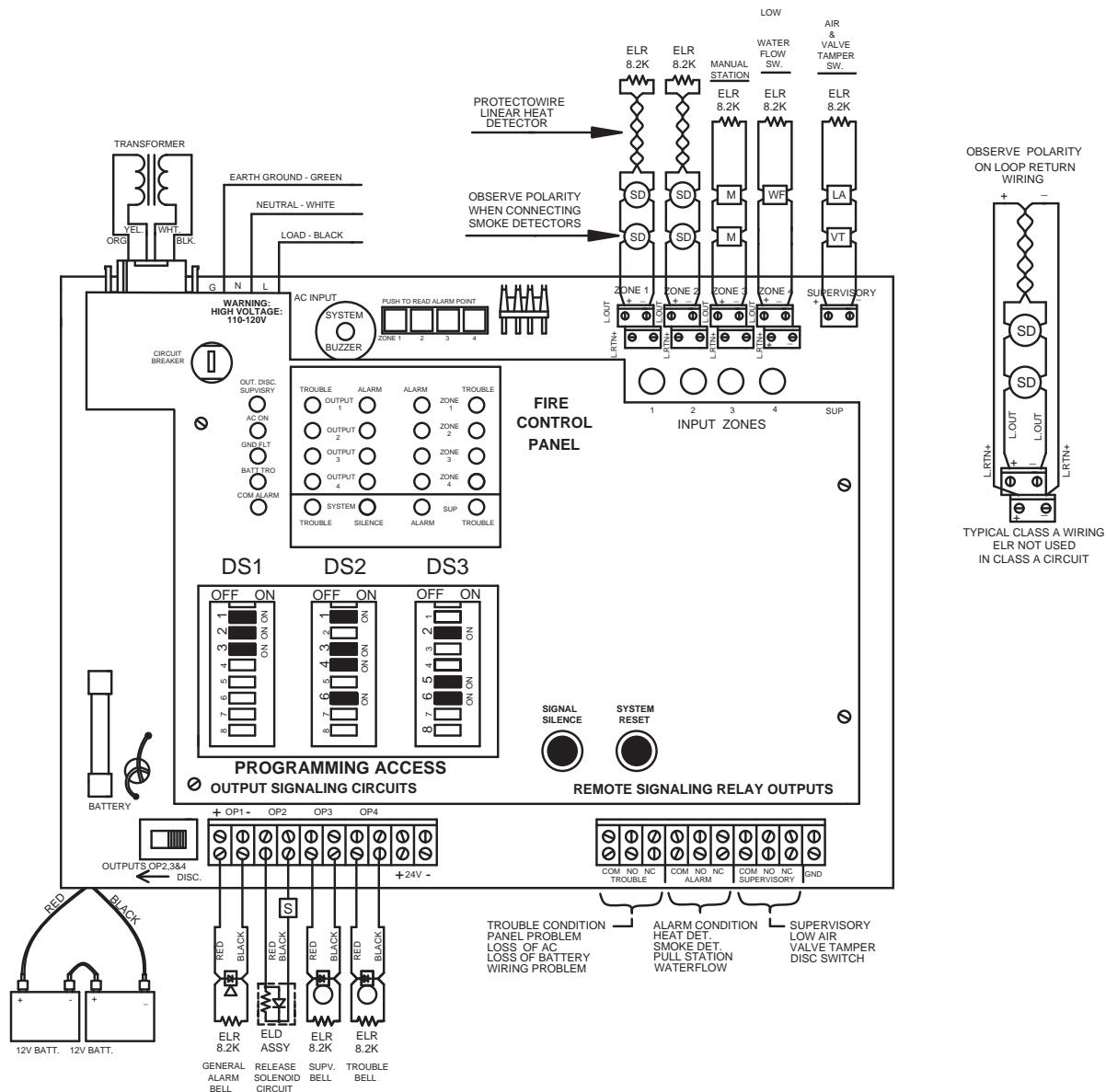

Description: Single release - three zone with trouble bell.

Inputs: (2) IDC zones, (1) manual pull zone, (1) waterflow zone, (1) supervisory zone

Outputs: (1) general alarm bell ckt, (1) solenoid release ckt, (1) supervisory bell ckt, (1) trouble bell ckt.

Operation: Activation of either IDC zone or manual pull zone will operate the release circuit and general alarm output bell.

Activation of the waterflow zone will operate the general alarm bell.

Activation of the supervisory zone will operate the supervisory bell.

A trouble condition (low/disc. battery, wire problem, etc.) will operate the trouble bell.

When either Zone 1, 2 or 3 is in alarm - Output #1 (general alarm) and Output #2 (solenoid release) will operate.

When Zone 4 is in alarm - Output #1 will operate the general alarm bell.

When the supervisory zone is activated - Output #3 (supervisory bell) will operate.

When the panel is in trouble condition - Output #4 (trouble bell) will operate.

Note: Output #3 Alarm & Trouble indicator will activate when disconnect switch is thrown. Supervisory bell must provide a distinct sound which is different than alarm bell.

WIRING DIAGRAM PROGRAM #6
SINGLE RELEASE, TWO ALARM (IDC) ZONES, WITH
ONE WATERFLOW ZONE AND TWO SUPERVISORY ZONES WITH SYSTEM
TROUBLE/SUPERVISORY OUTPUT BELL CIRCUIT

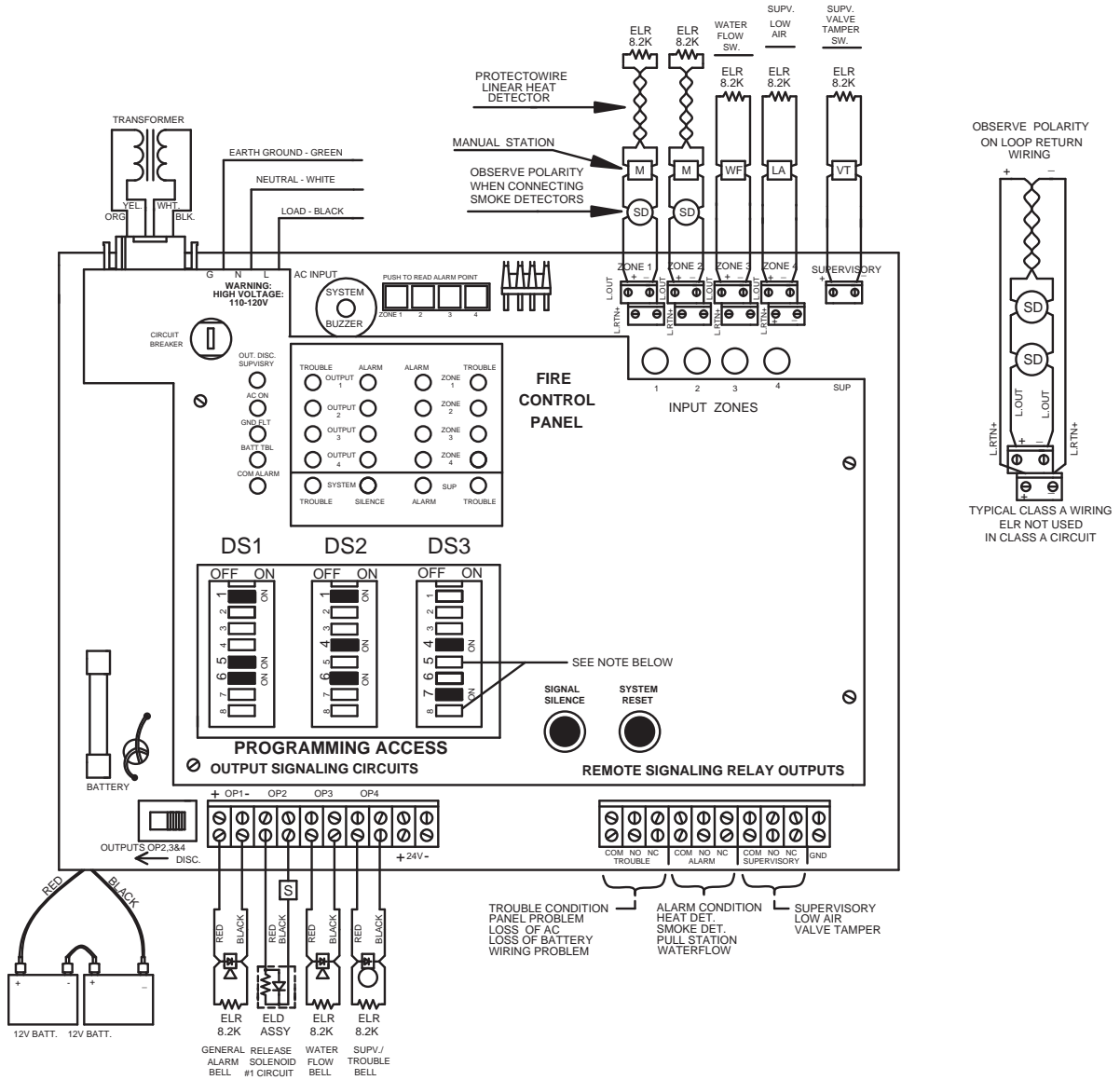

Description: Single release - two zones / supervisory.

Inputs: (2) IDC zones, (1) waterflow zone, (2) supervisory zones.

Outputs: (1) general alarm bell, (1) solenoid release ckt, (1) waterflow bell, (1) supervisory/trouble bell ckt.

Operation: Activation of either IDC zone will operate the solenoid release and the general alarm bell.

Activation of the waterflow zone will operate the waterflow bell.

Activation of either the low air zone or the supervisory zone will operate the supv./tro. bell.

A trouble condition (low/disc. battery, wire problem etc.) will operate the supv./tro. bell.

When either Zone 1 or 2 is in alarm - Output #1 (general alarm) and Outputs #2 (solenoid #1) will operate.

When Zone 3 is in alarm - Output #3 (waterflow bell) will operate.

When either Zone 4 or the supervisory zone are activated - Output #4 (supv. only) will operate.

Note: DS3, SW5 & 8 placed to the "ON" position for Output #4 to activate on either supervisory or trouble signals. Supervisory bell must provide a distinct sound which is different than alarm bell.

revised 3-31-2008

WIRING DIAGRAM PROGRAM #7

SINGLE RELEASE, TWO ALARM ZONES (CROSS-ZONED), ONE WATERFLOW ZONE WITH OUTPUT CKT AND TWO SUPERVISORY ZONES WITH SYSTEM SUPERVISORY/TROUBLE BELL CIRCUIT

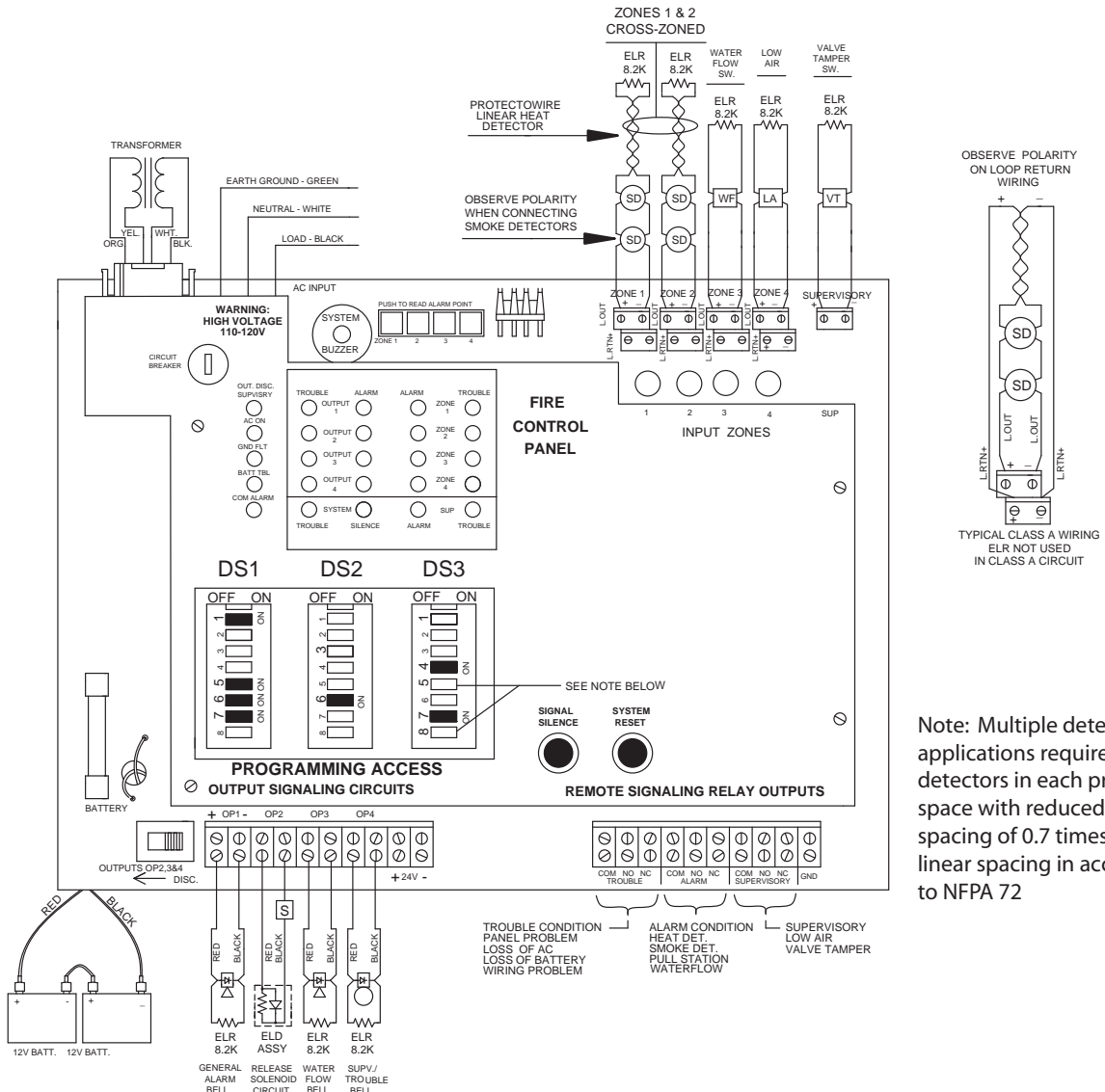

Description: Single release, two zones (cross-zoned) with two supervisory zones.

Inputs: (2) IDC zones (cross-zoned), (1) waterflow zone, (1) low air zone, (1) supervisory zone.

Outputs: (1) general alarm bell, (1) solenoid release, (1) waterflow bell, (1) supervisory/trouble bell.

Operation: Activation of both IDC zone at the same time will operate the solenoid release circuit and the general alarm output circuit.

Activation of either IDC zone will operate the general alarm output.

Activation of the waterflow zone will operate the waterflow bell output circuit.

Activation of either the low air zone or the supervisory zone will operate the supv./trouble bell circuit.

A trouble condition (low/disc. battery, wire problem etc.) will operate the supv./tro. bell.

When either Zone 1 or 2 is in alarm - Output #1 will operate (general alarm bell).

When Zones 1 and 2 are in alarm at the same time - Output #2 will operate (solenoid release and Output #1 general alarm) will operate.

When Zone 3 is in alarm - Output #3 will operate the waterflow bell circuit.

When either Zone 4 or the supervisory zone is activated - Output #4 will operate supv. bell.

Note: DS3, SW5 & 8 placed to the "ON" position for Output #4 to activate on either supervisory or trouble signals. Supervisory bell must provide a distinct sound which is different than alarm bell.

revised 3-31-2008

WIRING DIAGRAM PROGRAM #8

SINGLE RELEASE, ONE ALARM (IDC) ZONE (CROSS-ZONED) WITH LOW AIR ZONE,
ONE MANUAL STA. ZONE, ONE WATERFLOW ZONE, AND ONE SUPERVISORY ZONE
WITH SUPERVISORY/TROUBLE BELL OUTPUT

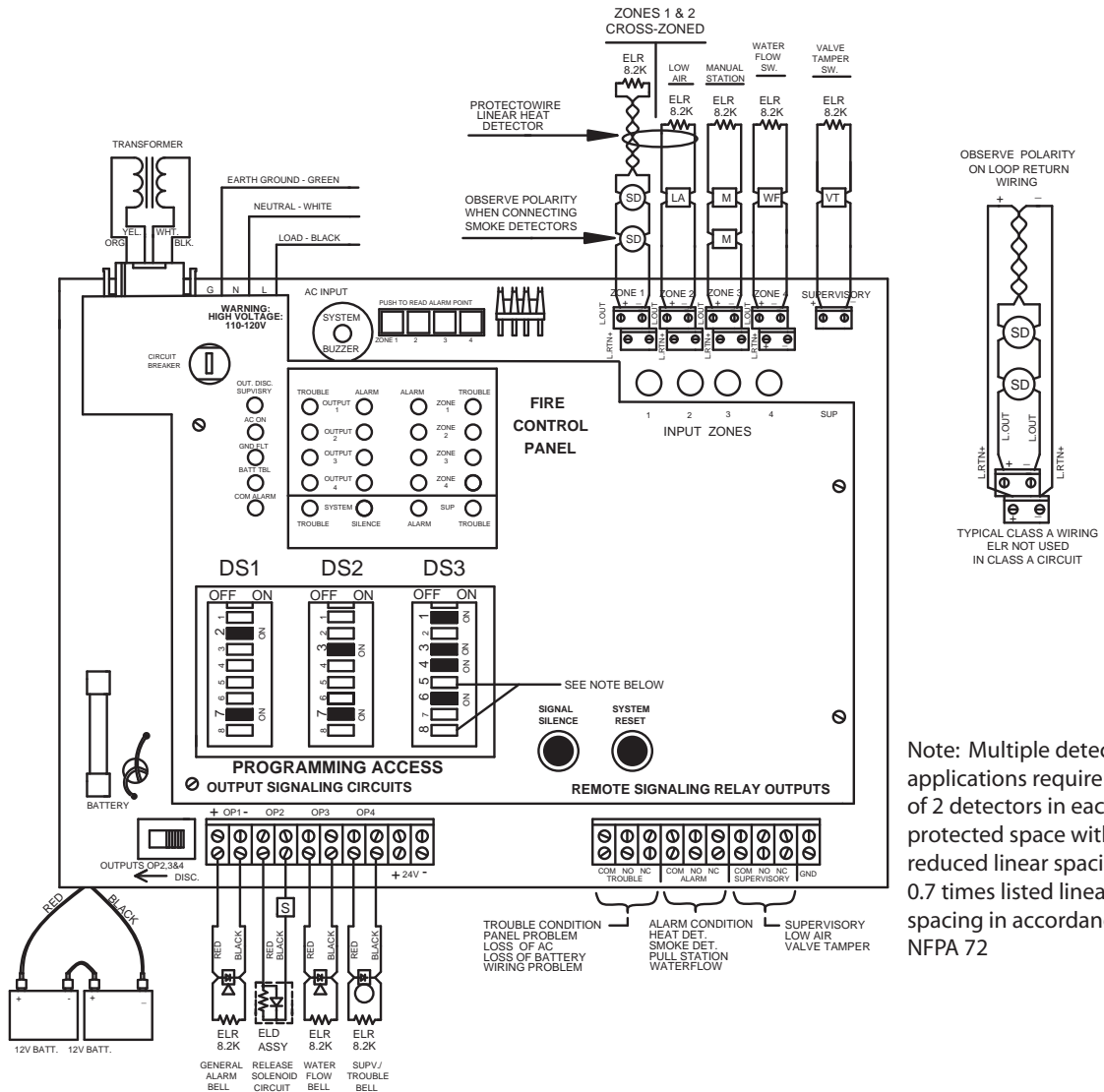

Description: Single release, one IDC zone (cross-zoned) with low air zone, with manual sta. override.
Inputs: (2) zones (cross-zoned), (1) manual pull zone, (1) waterflow zone, (1) supervisory zone
Outputs: (1) general alarm bell, (1) solenoid release, (1) waterflow bell, (1) supervisory/trouble bell.
Operation: Activation of both IDC Zone #1 and low air Zone #2 at the same time or the manual pull zone will operate the release solenoid Output #2 and the general alarm Output #1 circuit
 Activation of Zone #1 will operate the general alarm output.
 Activation of the low air Zone #2 will operate the supervisory/trouble bell (#4 output).
 Activation of the waterflow Zone #4 will operate the waterflow bell #3 output circuit.
 Activation of the supervisory zone will operate the supervisory/trouble bell #4 output circuit.
 A trouble condition (low/disc. battery,wire problem etc.) will operate the supv./tro. bell.
 When Zone 1 is in alarm - Output #1 will operate (general alarm bell).
 When Zone 3 is in alarm - Outputs #2 (solenoid release) and #1 (general alarm) will operate.
 When Zones 1 and 2 are in alarm at the same time - Output #2 will operate (solenoid release).
 When Zone 4 is in alarm - Output #3 will operate the waterflow bell #3 output circuit.
 When the supervisory zone is activated - Output #4 will operate supervisory bell.

Note: DS3, SW5 & 8 placed to the "ON" position for Output #4 to activate on either supervisory or trouble signals. Supervisory bell must provide a distinct sound which is different than alarm bell.

revised 3-31-2008

WIRING DIAGRAM PROGRAM #9

TRIPLE, SPLIT RELEASE, THREE ALARM (IDC) ZONES,
ONE WATERFLOW ZONE AND ONE SUPERVISORY ZONE

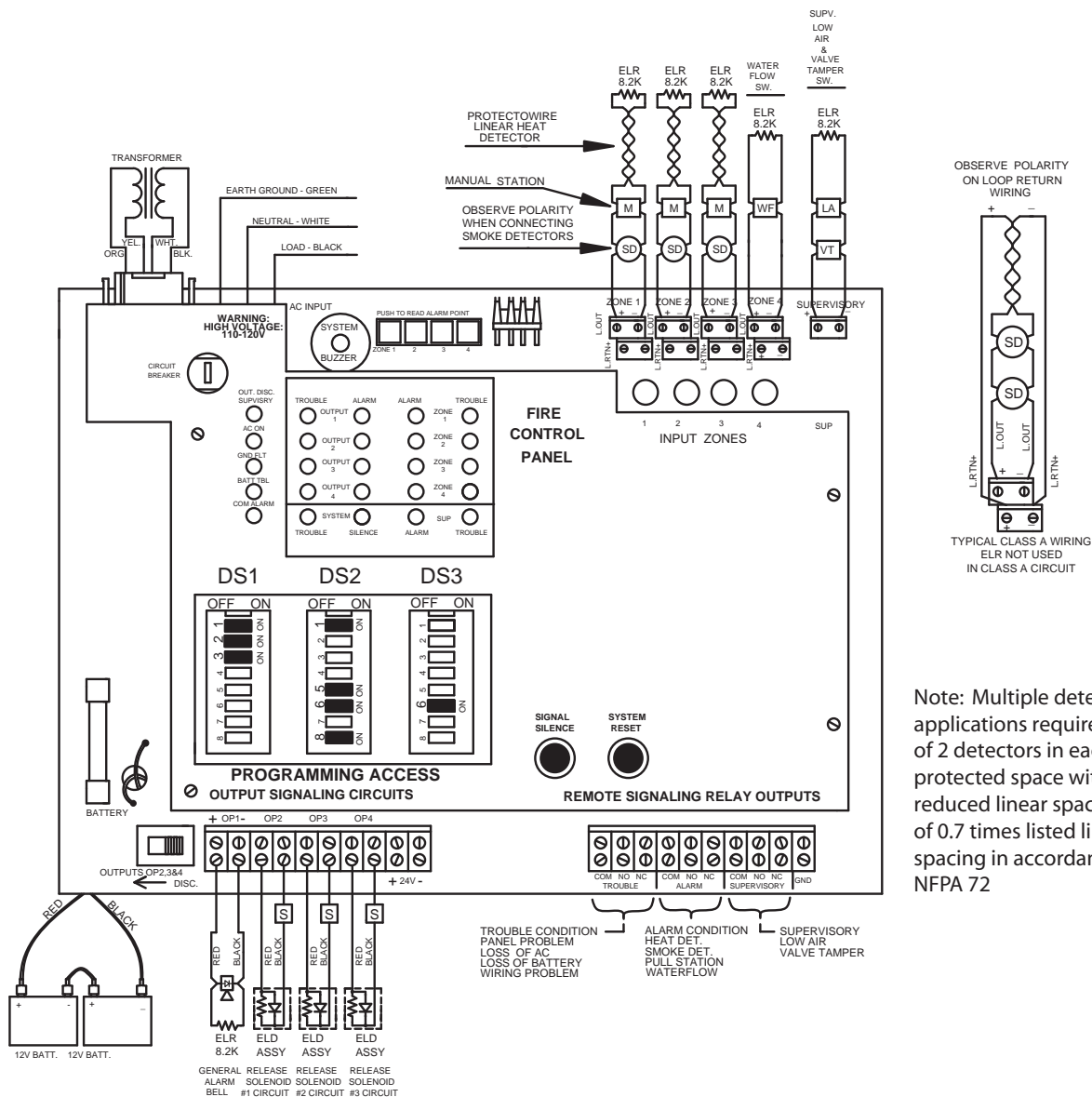

Note: Multiple detector applications require min. of 2 detectors in each protected space with reduced linear spacing of 0.7 times listed linear spacing in accordance to NFPA 72

Description: Triple, split release - three zones

Inputs: (3) IDC zones, (1) waterflow zone, (1) supervisory zone

Outputs: (1) general alarm bell ckt, (3) solenoid release circuits.

Operation: Activation of IDC Zones #1 will operate solenoid release #1 (Output #2) and the general alarm bell.

Activation of IDC Zone #2 will operate solenoid release #2 (Output #3) and gen. al. bell.

Activation of IDC Zone #3 will operate solenoid release #3 (Output #4) and gen. al. bell.

Activation of the waterflow Zone #4 will operate the general alarm bell.

Activation of the supervisory zone will operate the system buzzer.

When Zone 1 is in alarm - Output #1 (general alarm) and Outputs #2 (solenoid #1) will operate.

When Zone 2 is in alarm - Output #1 (general alarm) and Outputs #3 (solenoid #2) will operate.

When Zone 3 is in alarm - Output #1 (general alarm) and Outputs #4 (solenoid #3) will operate.

When Zone 4 is in alarm - Output #1 (general alarm) will operate.

When the supervisory zone is activated - the system buzzer will operate.

revised 3-31-2008

WIRING DIAGRAM PROGRAM #10

DUAL, SPLIT RELEASE, FOUR ALARM (IDC) ZONES (TWO EACH CROSS-ZONED)
AND ONE SUPERVISORY ZONE WITH SUPERVISORY/TROUBLE BELL OUTPUT CKT.

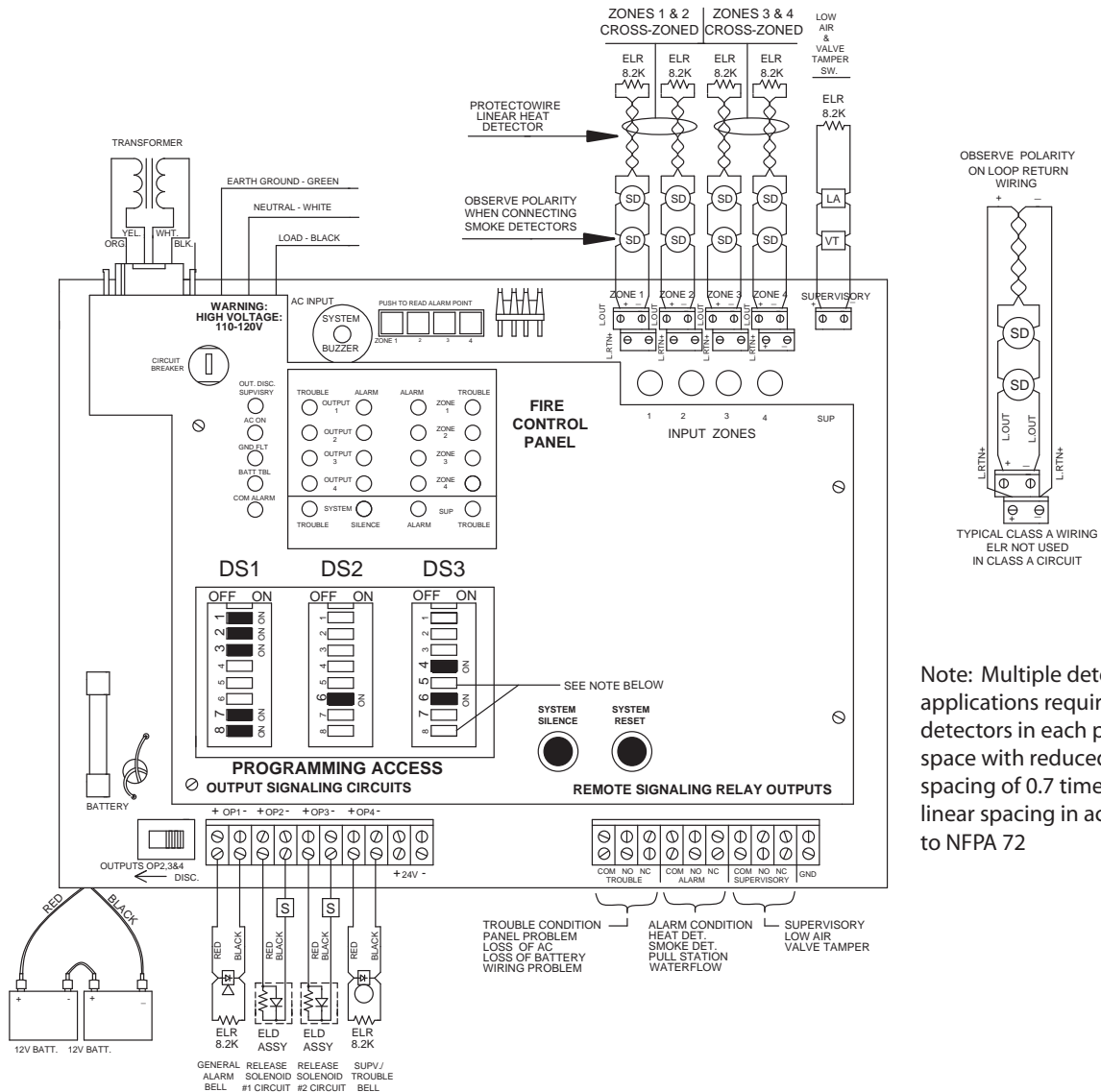

Description: Dual, split release, four alarm zones (two each cross-zoned).

Inputs: (4) IDC zones (2 each cross-zoned), (1) supervisory zone.

Outputs: (1) general alarm bell, (2) solenoid release, (1) supervisory/trouble bell.

Operation: Activation of both Zones #1 & #2 at the same time will operate solenoid release #1 (Output #2) and the general alarm bell.

Activation of both Zones #3 & #4 at the same time will operate solenoid release #2 (Output #3) and the general alarm bell.

Activation of any one IDC zone will operate the general alarm bell.

Activation of the supervisory zone will operate the supv./trouble bell (Output #4) circuit.

A trouble condition (low/disc. battery, wire problem etc.) will operate the supv./tro. bell.

When Zones 1, 2, 3 or 4 are in alarm - Output #1 will operate (general alarm bell).

When Zones 1 and 2 are in alarm at the same time - Output #2 will operate (solenoid release).

When Zones 3 and 4 are in alarm at the same time - Output #3 will operate (solenoid release).

When the supervisory zone is activated - Output #4 will operate the supv. bell Output #4 circuit.

Note: DS3, SW5 & 8 placed to the "ON" position for Output #4 to activate on either supervisory or trouble signals. Supervisory bell must provide a distinct sound which is different than alarm bell.

revised 3-31-2008

WIRING DIAGRAM PROGRAM #12

DUAL COMBINED RELEASE, ONE ALARM ZONE, CROSS-ZONED WITH LOW AIR ZONE,
ONE MANUAL STA. ZONE, ONE WATERFLOW ZONE, AND ONE SUPERVISORY ZONE
WITH SYSTEM TROUBLE/SUPERVISORY BELL OUTPUT CIRCUIT

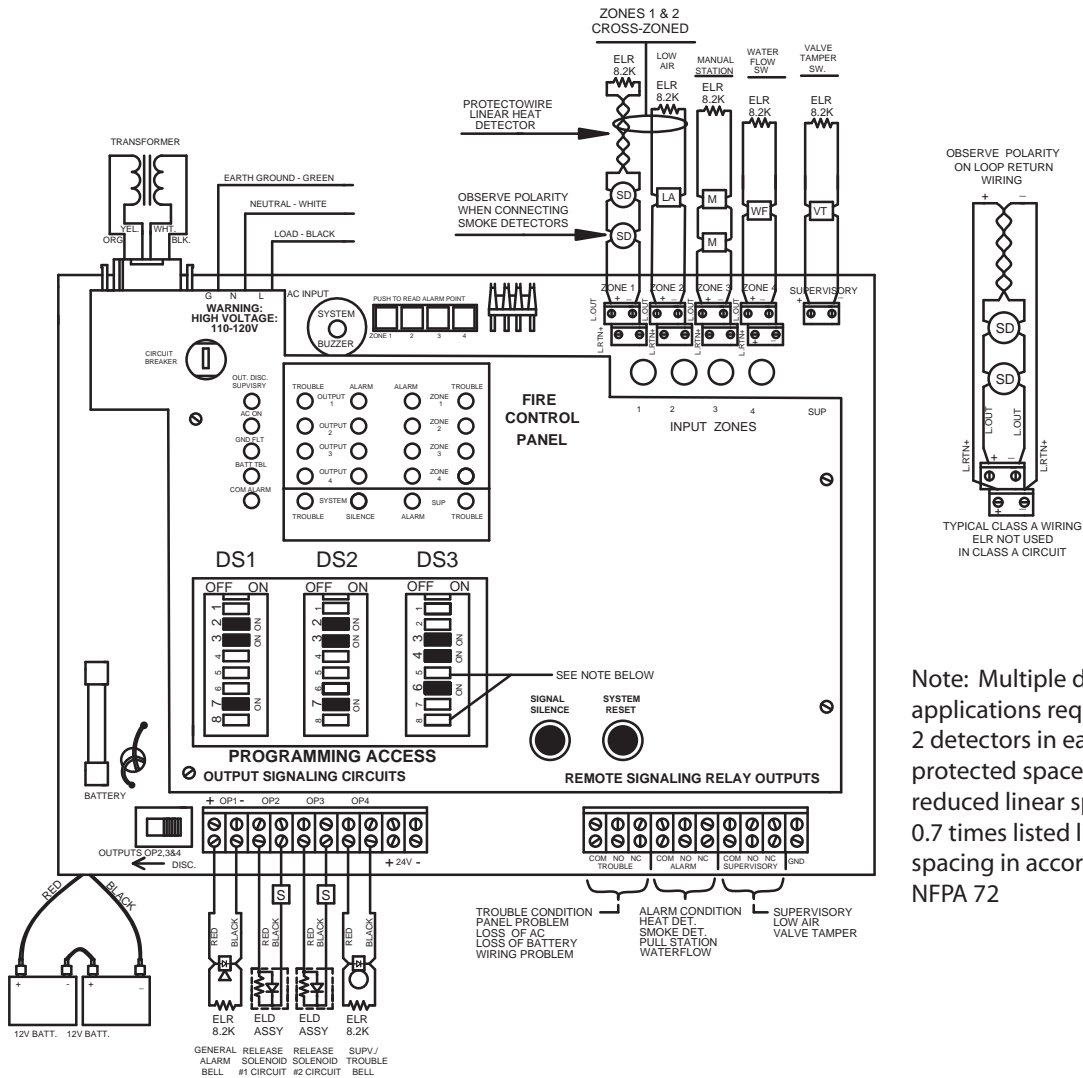

Note: Multiple detector applications require min. of 2 detectors in each protected space with reduced linear spacing of 0.7 times listed linear spacing in accordance to NFPA 72

Description: Dual combined release, one IDC zone, cross-zoned with low air zone and manual override.

Inputs: (1) IDC zone, (1) low air zone, (1) manual pull zone, (1) waterflow zone, (1) supervisory zone.

Outputs: (1) general alarm bell, (2) solenoid release ckt., (1) supervisory/trouble bell ckt.

Operation: Activation of both IDC Zone #1 & low air Zone #2 at the same time or manual pull zone will operate the solenoid release Outputs #2 & #3, and the general alarm bell Output #1.

Activation of the low air Zone #2 will operate the supv./tro. bell Output #4 circuit.

Activation of the waterflow Zone #4 will operate the general alarm bell (Output #1).

Activation of the supervisory zone will operate the supv./trouble bell (Output #4) circuit.

A trouble condition (low/disc. battery, wire problem etc.) will operate the supv./tro. bell.

When Zone 1 is in alarm - Output #1 will operate (general alarm bell).

When Zone 3 is in alarm - Outputs #2 and #3 will operate (solenoid release) and #1 (general alarm) will operate.

When Zone 4 is in alarm - Output #1 (general alarm) will operate.

When Zone 2 or the supervisory zone is activated - Output #4 will operate the supv. bell Output #4 circuit.

Note: DS3, SW5 & 8 placed to the "ON" position for Output #4 to activate on either supervisory or trouble signals. Supervisory bell must provide a distinct sound which is different than alarm bell.

WIRING DIAGRAM PROGRAM #13

DUAL COMBINED RELEASE, TWO ALARM (IDC) ZONES, EACH CROSS-ZONED WITH A LOW AIR ZONE, AND ONE SUPERVISORY ZONE WITH SYSTEM TROUBLE/SUPERVISORY BELL OUTPUT CIRCUIT

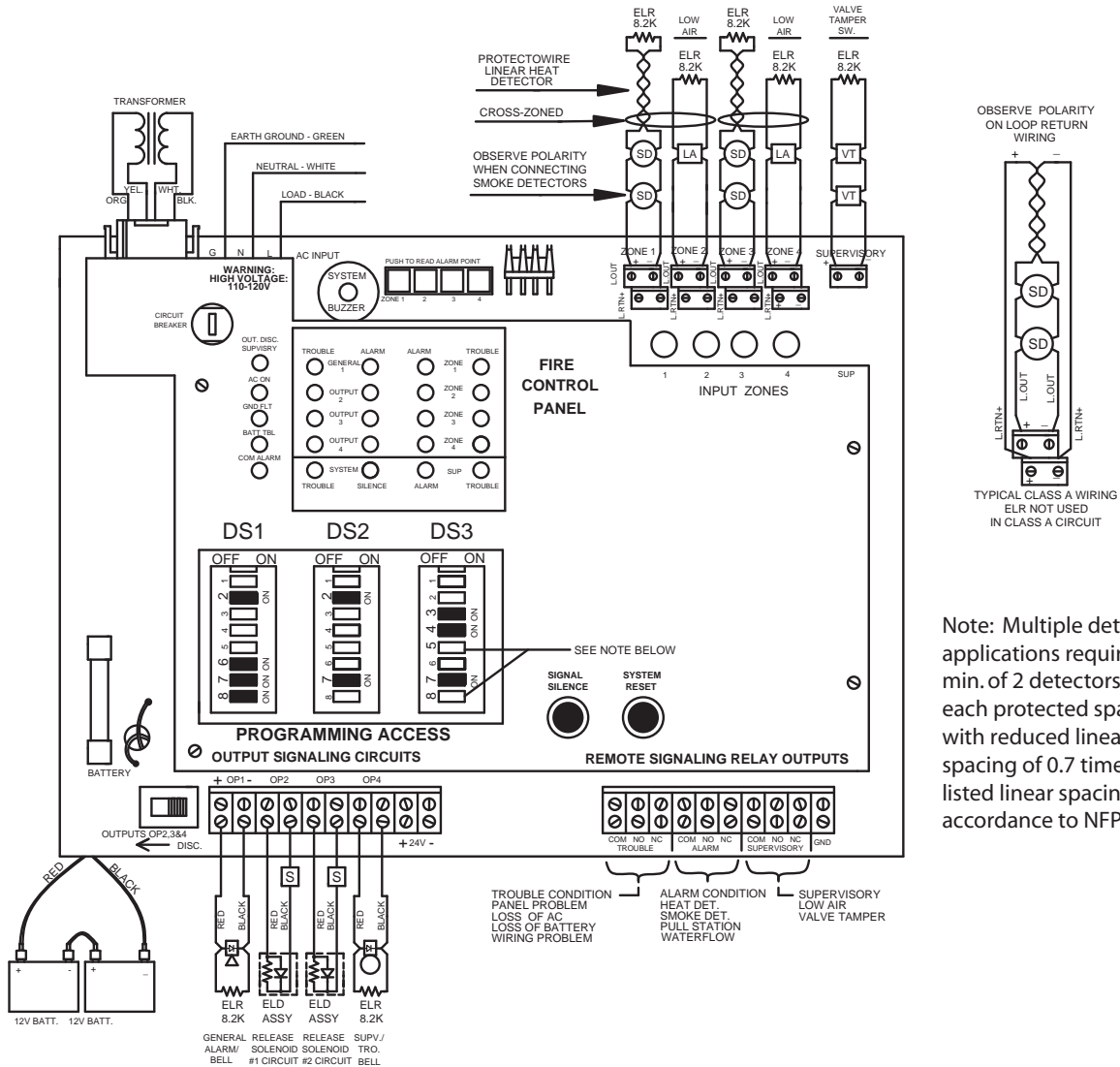

Description: Dual combined release, two IDC zones, each zone cross-zoned with a low air zone.

Inputs: (2) IDC zones, (2) low air zones, (1) supervisory zone.

Outputs: (1) general alarm bell, (2) solenoid release circuits, (1) supervisory/trouble bell ckt.

Operation: Activation of both IDC Zone #1 and low air Zone #2 at the same time will operate the sol. release Outputs #2 and #3, the general alarm bell Output #1, and supv./tro. Output #4. Activation of both IDC Zone #3 and low air Zone #4 at the same time will operate the sol. release Outputs #2 and #3, the general alarm bell Output #1, and supv./tro. Output #4. Activation of the low air Zone #2 or #4 will operate the supv./tro. bell Output #4 circuit. Activation of IDC Zone #1 or Zone #3 will operate the general alarm bell (Output #1). Activation of the supervisory zone will operate the supv./tro. bell Output #4.

When Zone 1 or Zone 3 is in alarm - Output #1 will operate the general bell.

When Zone 1 and Zone 2 are in alarm - Outputs #2 & #3 (solenoid release) and #1 will operate.

When Zone 3 and Zone 4 are in alarm - Outputs #2 & #3 (solenoid release) and #1 will operate.

When Zone 2 or 4 or the supervisory zone is activated - Output #4 will operate the supv. bell.

Note: DS3, SW5 & 8 placed to the "ON" position for Output #4 to activate on either supervisory or trouble signals. Supervisory bell must provide a distinct sound which is different than alarm bell.

revised 3-31-2008

WIRING DIAGRAM PROGRAM #14

DUAL SPLIT RELEASE, TWO ALARM (IDC) ZONES, EACH CROSS-ZONED WITH A LOW AIR ZONE, ONE SUPERVISORY ZONE AND SYSTEM TROUBLE/SUPERVISORY BELL OUTPUT CIRCUIT

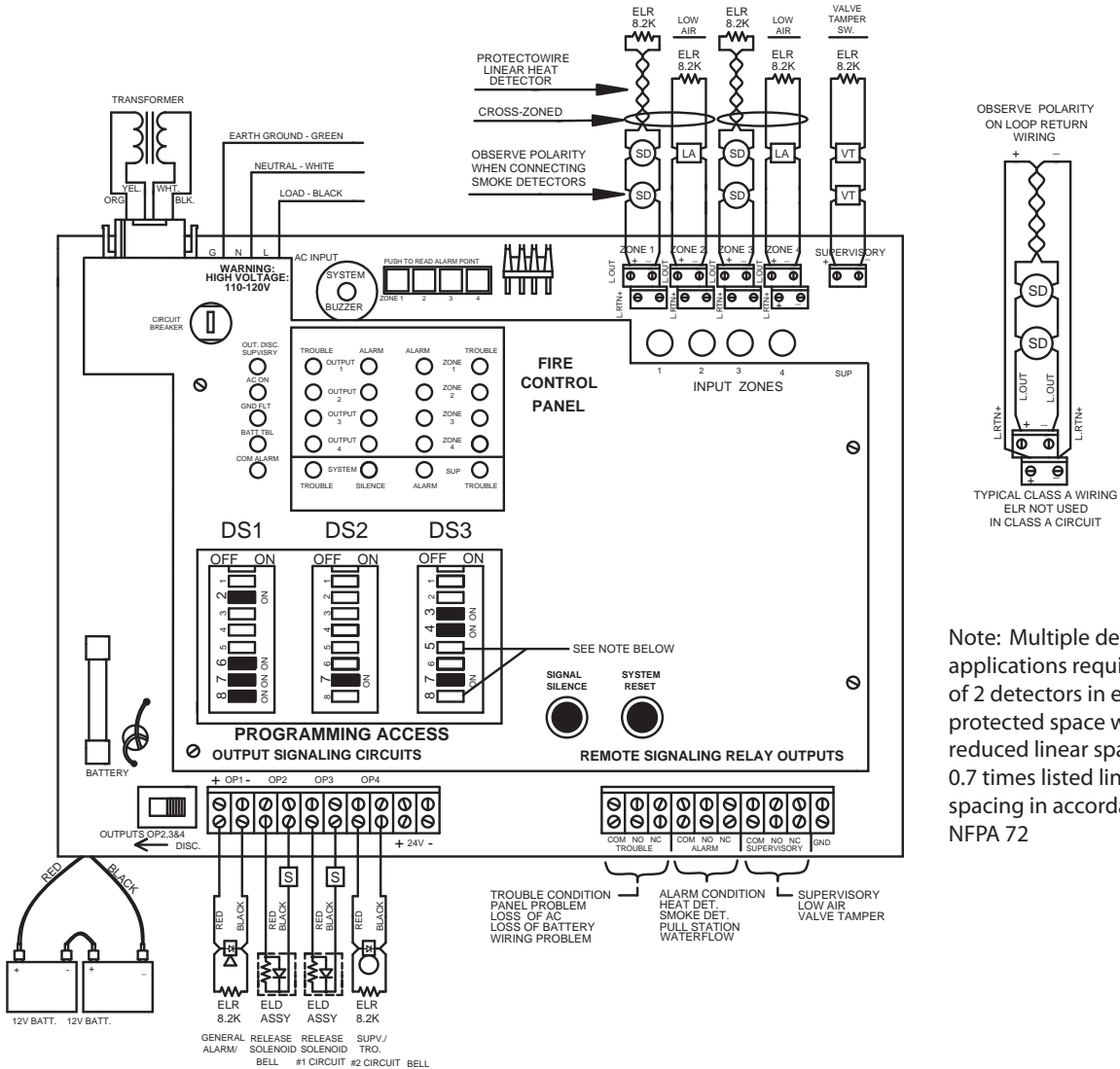

Note: Multiple detector applications require min. of 2 detectors in each protected space with reduced linear spacing of 0.7 times listed linear spacing in accordance to NFPA 72

Description: Dual split release, two IDC zones, each zone cross-zoned with a low air zone.
Inputs: (2) IDC zones, (2) low air zones, (1) supervisory zone.
Outputs: (1) general alarm bell, (2) solenoid release circuits, (1) supervisory/trouble bell ckt.
Operation: Activation of both IDC Zone #1 and low air Zone #2 at the same time will operate the sol. release Output #2, the general alarm bell Output #1 and the supv./tro. Output #4. Activation of both IDC Zone #3 and low air Zone #4 at the same time will operate the sol. release Output #3, the general alarm bell Output #1 and the supv./tro. Output #4. Activation of the low air Zone #2 or #4 will operate the supv./tro. bell Output #4 circuit. Activation of IDC Zone #1 or Zone #3 will operate the general alarm bell (Output #1). Activation of the supervisory zone will operate the supv./tro. bell Output #4.

When Zone 1 or Zone 3 is in alarm - Output #1 will operate the general bell.
 When Zone 1 and Zone 2 are in alarm - Outputs #2 (solenoid release) and #1 will operate.
 When Zone 3 and Zone 4 are in alarm - Outputs #3 (solenoid release) and #1 will operate.
 When Zone 2 or 4 or the supervisory zone is activated - Output #4 will operate the supv. bell.

Note: DS3, SW5 & 8 placed to the "ON" position for Output #4 to activate on either supervisory or trouble signals. Supervisory bell must provide a distinct sound which is different than alarm bell.

revised 3-31-2008

WIRING DIAGRAM PROGRAM #15

FOUR ALARM (IDC) ZONES WITH INDIVIDUAL ZONE ALARM OUTPUT (NAC)S

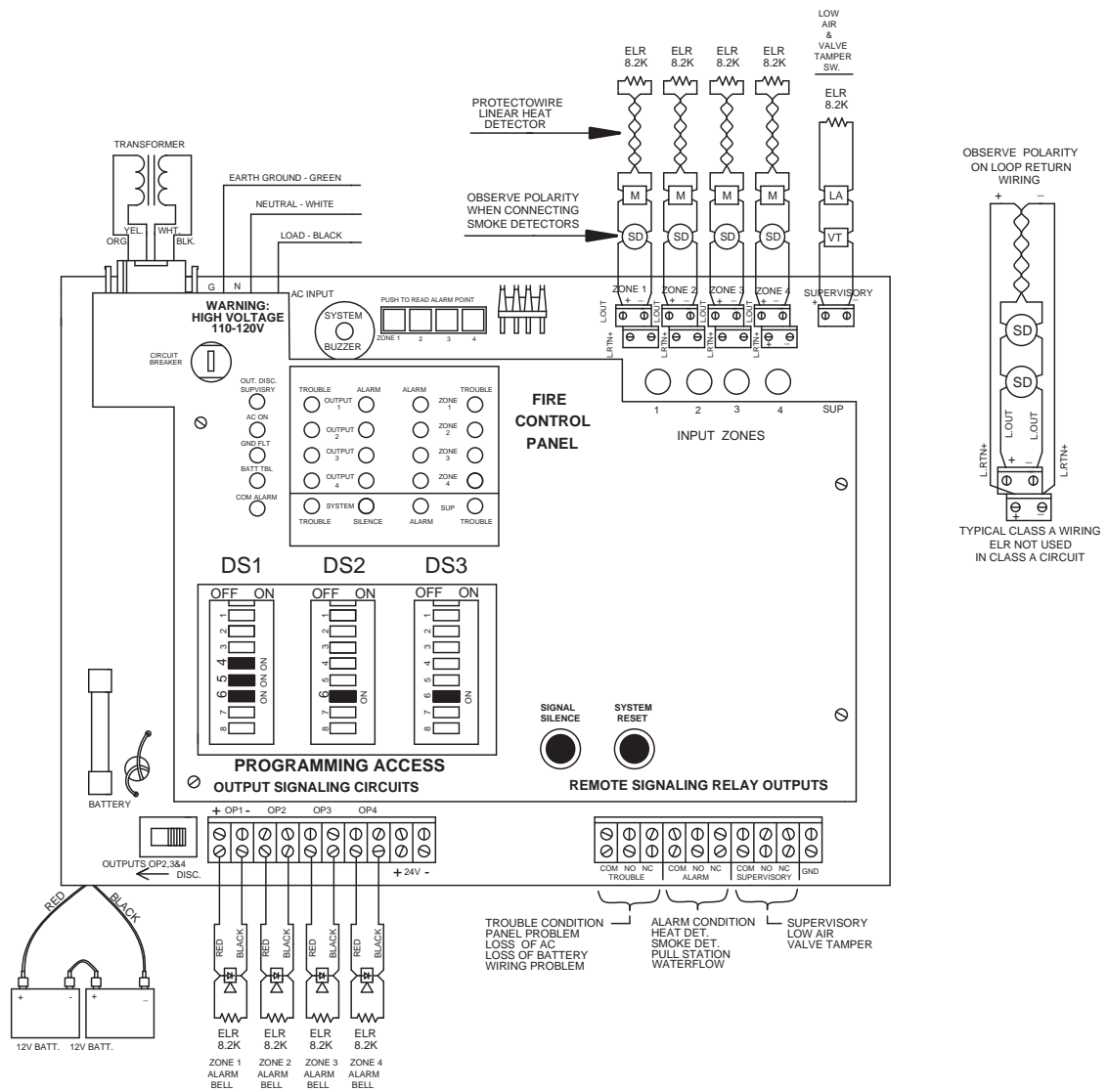

Description: Four Alarm (IDC) zones with individual zone alarm outputs.

Inputs: (4) IDC zones, (1) supervisory zone.

Outputs: (4) zone alarm bell ckts.

Operation: Activation of IDC Zone #1 will operate the zone alarm bell, Output #1.

Activation of IDC Zone #2 will operate the zone alarm bell, Output #2.

Activation of IDC Zone #3 will operate the zone alarm bell, Output #3.

Activation of IDC Zone #4 will operate the zone alarm bell, Output #4.

When the supervisory zone is activated - the panel system buzzer will operate.

Note: Supervisory bell must provide a distinct sound which is different than alarm bell.

WIRING DIAGRAM PROGRAM #16

FOUR ALARM (IDC) ZONES WITH FOUR (NAC) GENERAL ALARM OUTPUTS

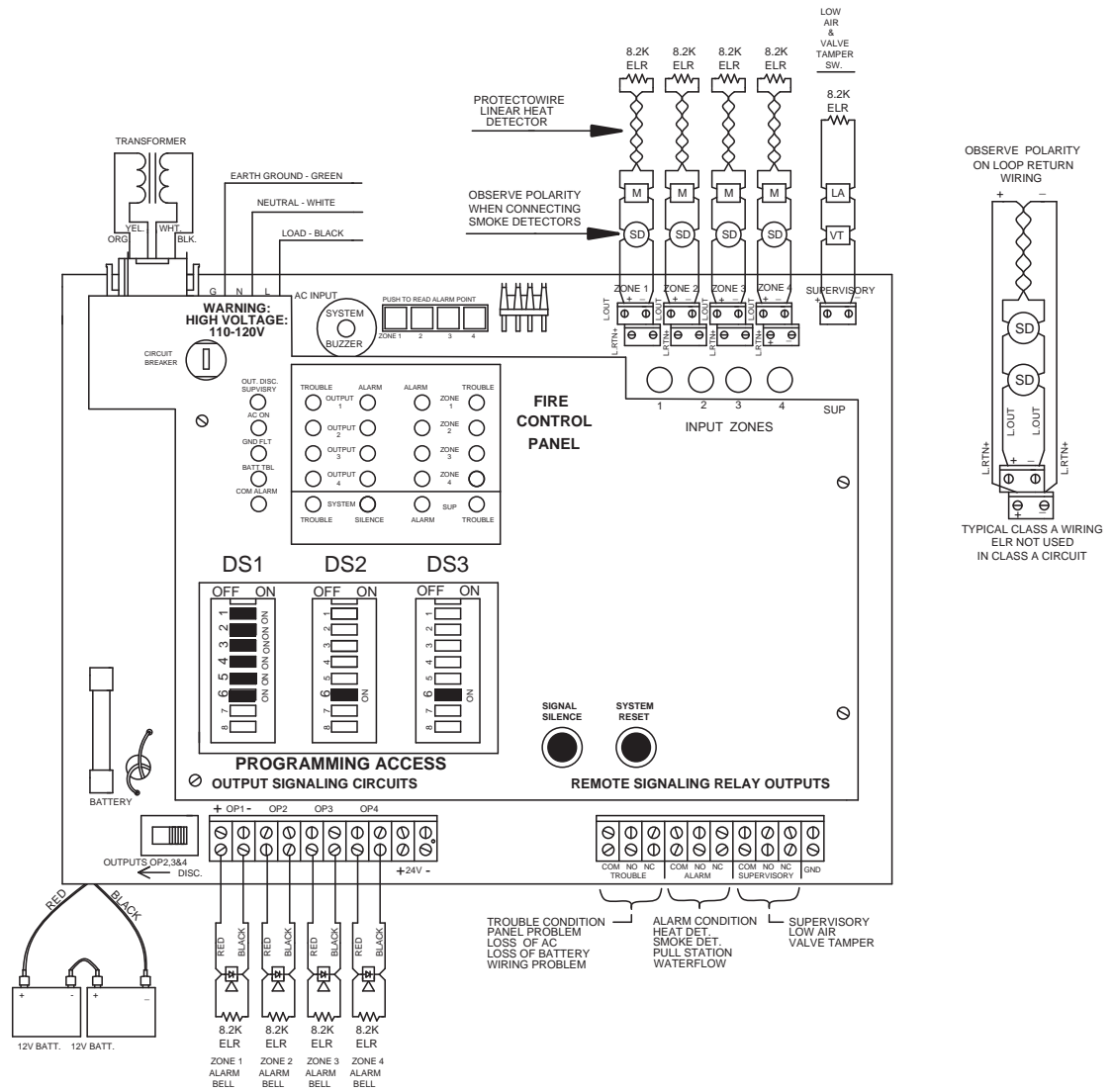

Description: Four Alarm (IDC) zones with four (NCC) general alarm output circuits.

Inputs: (4) IDC zones, (1) supervisory zone.

Outputs: (4) zone alarm bell ckt.

Operation: Activation of any IDC zone will operate all (4) alarm bell output circuits.

When the supervisory zone is activated - the panel system buzzer will operate.

Note: Supervisory bell must provide a distinct sound which is different than alarm bell.

SRP-4x4 Fire Alarm Control Panel Battery Calculation Sheet

Use this form to calculate the required battery size for your system. First determine the duration the panel will need to function on batteries in hours.

-For Factory Mutual insured premises, 24 hrs is required for Local Systems, 60 hrs for Off Premise and 90 hrs for Releasing Systems.

-For UL insured premises 24 hrs battery back-up is intended for Local, Proprietary and Central Station Signaling Systems

-Secondly after the batteries have exceeded their time duration, the panel must operate in full alarm mode an additional 15 minutes or 0.25 hrs.

Follow the formulas and tables below to calculate the required batteries for your system.

FORMULAS AND VARIABLES		
System Standby Current in amperes = (I1)	Standby Time in Hours (H1)	Battery Size De-rate Divisor = (0.85)
System Alarm Current in amperes = (I2)	Alarm time in Hours = (H2)	
System Battery Size required in amperes hours - $[(I1 \times H1) + (I2 \times H2)] / 0.85 = \text{Battery Size (AH)}$		

SYSTEM STANDBY CURRENT CALCULATIONS (I2)				
Description	Quantity	X	Current	Product
Base SRP-4x4 System	1	X	.160 A	.160 A
Utilizing On Board 24 Volt Auxiliary Power		X	.100 A	
			Total (I1)	

SYSTEM ALARM CURRENT CALCULATIONS (I2)				
Device Description	Quantity	X	Current	Product
PDM-1000-4 Digital Alarm Point Location Meter		X	0.100A	
RB-4 Auxiliary Relay Module		X	0.052A	
AM-91-2 Class A Alarm N.A.C. Adapter		X	0.004A	
Solenoid Valve (See Complete list and current draw on pg 43)		X		
MB Bells (Wheelock)		X	0.030 A	
SZ5424 Series Horn/Strobe (Amesco)		X	0.250 A	
450 Vibratone Horn (Federal)		X	0.025 A	
VALS -24 Strobe Light (Federal)		X	0.080 A	
SFH Speaker / Strobe Combination (Amesco)		X	0.114 A	
MTWP Series Horn / Strobe (Wheelock)		X	0.126 A	
See Complete list and current draw on page 44				
			Subtotal	
System Standby Current (Total I1 from Calculations above)	1	X		
			Total (I2)	

SYSTEM BATTERY SIZE CALCULATIONS	
$[(I1 \times H1) + (I2 \times H2)] / 0.85 = \text{Minimum AH}$	
$[(\quad \times \quad) + (\quad \times \quad)] / 0.85 = \quad \text{AH}$	
H1= 24 Hours Local	H2= 0.25 Hrs Required per FM
H1= 60 Hours Off Premise	Note: Use next largest available battery size
H1= 90 Hours Required by FM (Releasing Systems)	
From the chart to the right, select the available battery size for your panel Maximum available batteries for UL requirements are PS12180	

AVAILABLE BATTERIES		
Catalog #	Rating (AH)	Battery Cabinet
PS1270	7.0 AH	E.5 (red)
PS6100	12.0 AH	E.5 (red)
PS12180	18.0 AH	E.5 (red) Required
PS12330	33.0 AH	E.5 (red) Required

Battery Maintenance and Testing: Batteries shall be tested and inspected per NFPA 72, on a quarterly basis. While in a standby state the floating voltage shall be 27.6 Volts, if battery voltage drops below 24.6 Volts then replace batteries with a 2.2K resistor. If voltage across resistor is 27 Volts then the batteries need to be replaced. If voltage across resistor is less than 26 volts contact Protectowire. If the batteries show any visual defects of swelling, cracking or severe corrosion then they should be replaced immediately. Life expectancy is typically 3-5 years, to preempt failure, batteries should be replaced every 3-4 years.

SRP-4x4 SERIES FIRE ALARM CONTROL PANEL INSTRUCTIONS

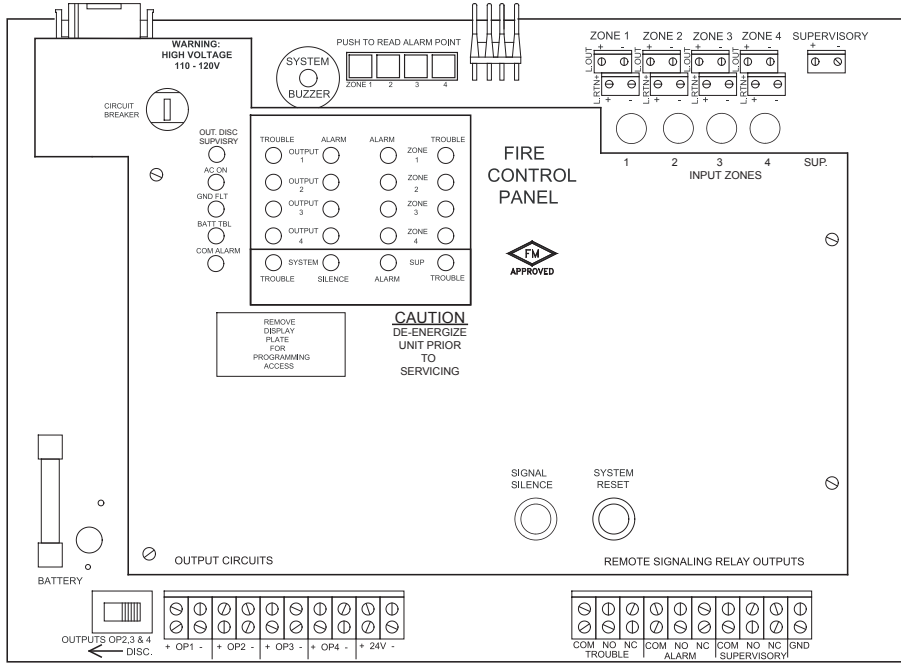

IMPORTANT:
THESE INSTRUCTIONS *MUST* BE MOUNTED ON THE CABINET FRONT OR FRAMED AND MOUNTED ADJACENT TO THE ENCLOSURE

Name:	
Address	
Phone #	
Model #	SRP-4x4
REFERENCE: SRP-4x4 operating & maintenance manual dated 2-5-14	
Part Number:	DS-9195
Revision Level:	B

SYSTEM RESET	System Reset Button: Press to reset system from ALARM condition.
SIGNAL SILENCE	Alarm / Trouble Silencing Button: Press to silence both Alarm and/or Trouble Signal for on board piezo buzzer. Also silences Alarm signal for any Notification Appliance Circuits
OUTPUT DISC. SW.	Output disconnect switch; Slide to left position to inhibit output signals for OP2, 3 & 4
ADDITIONAL PUSHBUTTONS: FOR UTILIZING THE ALARM POINT LOCATION METER PDM-1000-4	
METER READ SWITCHES	Press and hold to read distance (ft/m) to alarm actuation point of Protectowire zone in Alarm. Switches read from left to right with Zone 1 (first pushbutton), Zone 2 (second pushbutton), Zone 3 (third pushbutton) and Zone 4 (fourth pushbutton)

OUT. DISC. SUPVISRY	YELLOW	Output Disconnect Indicator, On when Disconnect Switch in the out position
AC ON	GREEN	A.C.Power Indicator; Panel AC voltage is present
GND FLT	YELLOW	System Ground Fault Indicator: On when undesirable positive or negative current leakage occurs to ground from a DC power supply of system
BATT TBL	YELLOW	On when batteries are in a trouble condition
COM ALARM	RED	Common Alarm indicator; Activated when any Alarm condition (Non-Supervisory) exists
SYSTEM TROUBLE	YELLOW	System trouble indicator; On when system is in a TROUBLE condition
SYSTEM SILENCE	YELLOW	System silence indicator; On when SYSTEM TROUBLE has been silenced
SUP. ALARM	YELLOW	On when Supervisory Alarm condition exists
SUP. TROUBLE	YELLOW	On when Supervisory Trouble condition exists
OUTPUT 1 ALARM	RED	System Alarm indicator; Activated when any Alarm condition exists
OUTPUT 1 TROUBLE	YELLOW	On when OUTPUT circuit #1 is in a Trouble condition
OUTPUT 2, 3 & 4 ALARM	RED	Individual Output Alarm indicators; On when corresponding OUTPUT zone is in ALARM
OUTPUT 2, 3 & 4 TROUBLE	YELLOW	Individual Output Trouble indicators; On when corresponding OUTPUT zone is in TROUBLE condition
ZONE 1, 2, 3 & 4 ALARM	RED	Individual Zone Alarm indicators; On when corresponding DETECTION ZONE is in ALARM state
ZONE 1, 2, 3 & 4 TROUBLE	YELLOW	Individual Zone Trouble indicators; On when corresponding DETECTION ZONE is in TROUBLE state

APPENDIX A

The following Smoke Detectors/ Solenoids / Notification Appliance Circuits (NAC's) are all approved by UL for use in the SRP-4x4 Unless otherwise noted.

UL Compatibility Identifier for smoke detectors are listed under **SRP**.

Per UL 864 9th edition stipulation has been added that two wire smoke detectors of different models are not to be mixed or matched on a system. Maximum number of **Hochiki** smoke detectors per Zone=20

Voltage Range: 15.7-25.6 Volts.

DET. MODEL	IDENTIFIER	BASE MODEL	IDENTIFIER
SLR-24V	HD-3	NS6-220	HB-3
SLR-24H	HD-3	NS6-220	HB-3
SIJ-24	HD-3	NS6-220	HB-3

Compatible 24 Volt Solenoids:

Solenoid	Power/ Current	FM Solenoid Group	Size NPS
ASCO MODEL: # T8210A107	16.8 WATTS, 700mA	B	1/2 in. NPS, 1/2 in orifice
ASCO MODEL:# R8210A107			
ASCO MODEL:# 8210A107			
ASCO MODEL: # 8210G207	10.6 WATTS, 440mA	D	1/2 in. NPS, 1/2 in orifice
ASCO MODEL:# HV2648571			
ASCO MODEL:# HV2648581			
SKINNER MODEL: # LV2LBX25	11 WATTS, 458mA	A	1/2 in. NPS, 1/2 in orifice
SKINNER MODEL: # 73218BN4UNLVNOC111C2	10 WATTS, 420mA	E	1/2 in. NPS, 5/8 in orifice
SKINNER MODEL:# 73212BN4TN00N0C111C2			1/2 in. orifice, 5-300 psi working pressure
SKINNER MODEL: # 73212BN4TNLVNOC322C2	22 WATTS, 920mA	F	1/2 in. orifice, 250 psi
SKINNER MODEL: # 71395SN2ENJ1NOH111C2 (FM APPROVED ONLY)	10 WATTS, 420mA	G	1/4 in. NPS, 1/16 in. orifice 250 psi working pressure
VICTAULIC SERIES 753-E	8.7 WATTS, 364mA	I	1/2 in. orifice 1/2 in. NPS
VIKING MODEL: # 11591, 11592, 11595, 11596	10 WATTS, 416mA	J	1/2 in. NPS 300 psi
VIKING MODEL: # 11601, 11602	9 WATTS, 375mA	K	1/2 in. NPS 250 psi

APPENDIX A (continued)

Per listing Agencies (UL / FM) only approved and tested 24 Volt Notification Appliance Circuits (NAC) can be installed on the SRP-4x4 Fire Control Panel. The following NAC devices are listed for use on the SRP-4x4 Panel.

Per UL listing, Output Circuit 1 has a maximum output rating of 1 Amp FWR. Wheelock P/N: ASWP-2475 is the only approved Horn listed for use on this circuit. When strobes and/or horns are used on Output Circuit 1 Synchronization module DSM-12/24R must be used in conjunction with the listed strobes.

Per UL listing, Output Circuits 2 thru 4 have a maximum output rating of .25 amps. Only 1 device may be installed on each output circuit 2-4 respectively.

* - Indicates Field Selectable Device

	NAC Type	Model / Series	Average Current
FEDERAL SIGNAL CORPORATION	Vibartone Horn	450	.25 Amps
	Low Profile Strobe	LP3 Series	.25 Amps
		LP6 Series	.25 Amps
		LP1 Series	.08 Amps
	Strobe Light	VALS Series	.08 Amps
AMESCO	Horns	H24W	.038 Amps
		HW-24	
		*BZ-54VT24	.050 Amps
		HP-24 / HP-24T	.015 Amps
	DC Motor Fire Alarm Bell	MBA-6-24	.012 Amps
		MBA-8-24	.025 Amps
		MBA-10-24	.023 Amps
	Strobe Light	*SAD24-75110	.250 Amps
		*SAD24-153075	.114 Amps
		SAD24-110	.200 Amps
		*SLW24W-75110	.122 Amps
		*SLW24-153075	.087 Amps
		SL3 Series	.030 Amps
		*SLW24W-75110	.120 Amps
	Horn/Strobe Combination	*SH24W-153075	.126 Amps
		*SHP24-75110	.250 Amps
		SLB24-75	.117 Amps
		SHB24-75	.144 Amps
		*SHW24W-75110	.150 Amps
		*SHW24-153075	.098 Amps
		*SZ5424 Series	.250 Amps
	Speaker Strobe Combination	*SFH45-75110	.250 Amps
*SFH47-75110		.250 Amps	

(Continued on next page)

APPENDIX A (continued)

Important: consult manufacture cut-sheet for actual current draw

*** - Indicates Field Selectable Device**

	NAC Type	Model / Series	Average Current
AMESCO	Strobe Light Retrofit	*RSD24-75110	.250 Amps
		*RSD24-153075	.114 Amps
		*RSB24-153075	
		RSD24-110	.200 Amps
	Temporal Module	TMP1-3A	.025 Amps
	Synchronization Module	SMS1-3A	.009 Amps
	Conical Strobe Light	SL-5 Series	.25 Amps
Wheelock ** Note: For Synchronization of strobes use DSM-12/24R Reference Wheelock data sheet #P83177V	Mini Horn	*MIZ Series	.017 Amps
	Multitone Electronic Appliance	*AMT Series	.098 Amps
	Motor Bell	MB Series	.030 Amps
	Speaker / Strobe	E70 Series	.171 Amps
		E90 Series	.238 Amps
	Audible Strobe	AH Series	.047 Amps
	Chime Strobe Combination	*CH70 Series	.161 Amps
		*CH90 Series	.238 Amps
	Horn Strobe Appliance	*NS Series	.183 Amps
		*NS4 Series	.206 Amps
	Weather Proof Strobe	RSSWP Series	.102 Amps
	Weather Proof Audible Strobe	ASWP Series	.145 Amps
		AHWP Series	.041 Amps
	Weather Proof Multitone Strobe	MTWP-24 Series	.126 Amps
	Weather Proof Multitone Horn	MT-24 Series	.040 Amps
	Weather Proof Speaker Strobe	ET70WP Series	.102 Amps
	**Synchronization Module	DSM-12/24R	.035 Amps
	Weather Proof Audible/Visual Combo	24V-MTWP Series	.145 Amps
	Vandal Resistant Speaker Strobe	ET-1080	.200 Amps

Note: Under a Sprinkler Supervisory Condition, the assigned Notification Appliance Circuit must have a distinct output signal from all other output notification circuits, therefore a Temporal Module from Appendix A must be added.

