

SURFACE MOUNT CEILING SPEAKER

PC-275AB-EB

Thank you for purchasing TOA's Wall Mount Speaker.
Please carefully follow the instructions in this manual to ensure long, trouble-free use of your equipment.

TABLE OF CONTENTS

1. SAFETY PRECAUTIONS	1	5. POLAR PATTERN	5
2. GENERAL DESCRIPTION AND FEATURES	2	6. FREQUENCY RESPONSE	5
3. INSTALLATION	3	7. SPECIFICATIONS	5
4. DIMENSIONAL DIAGRAM	4	احتياطات تتعلق بنواحي السلامة	6

1. SAFETY PRECAUTIONS

- Before installation or use, be sure to carefully read all the instructions in this section for correct and safe operation.
- Be sure to follow all the precautionary instructions in this section, which contain important warnings and/or cautions regarding safety.
- After reading, keep this manual handy for future reference.

WARNING

Indicates a potentially hazardous situation which, if mishandled, could result in death or serious personal injury.

When Installing the Unit

- Refer all installation work to the dealer from whom the speaker was purchased. Installation work requires extensive technical knowledge and experience. The speaker may fall off if incorrectly installed, resulting in possible personal injury.
- Install the speaker only in a location that can structurally support the full weight of the unit and mounting bracket. Doing otherwise may result in the speaker falling down and causing personal injury and/or property damage.
- Since the unit is designed for in-door use, do not install it outdoors. If installed outdoors, the aging of parts causes the unit to fall off, resulting in personal injury. Also, when it gets wet with rain, there is a danger of electric shock.
- Do not use other methods than specified to install the speaker. Extreme force is applied to the speaker and the speaker could fall off, possibly resulting in personal injuries.
- Use screws that are appropriate for the wall's material and structure. Failure to do so may cause the speaker to fall, resulting in material damage and possible personal injury.
- Ensure that all screws are securely tightened. If they are loose after installation, the speaker could fall down, possibly resulting in personal injury.
- Do not mount the speaker in locations exposed to constant vibration. The speaker or its mounts can

Traceability Information for Europe (EMC directive 2004/108/EC)

Manufacturer:
TOA Corporation
7-2-1, Minatojima Nakamachi, Chuo-ku, Kobe, Hyogo,
Japan

Authorized representative:
TOA Electronics Europe GmbH
Suederstrasse 282, 20537 Hamburg,
Germany

be damaged by excessive vibration, potentially causing the speaker to fall, which could result in personal injury.

- Do not use anti-rust lubricant. If it contacts resin or rubber parts, they could deteriorate and cause the speaker to fall, possibly resulting in personal injury.
- Do not install the speaker in indoor swimming pools or such locations where liquid chemicals are used. The parts deteriorate if corroded, causing the speaker to fall, which could result in personal injury.

When the Unit is in Use

- If any of the following irregularities occurs, immediately switch off the amplifier's power, and inform the shop from where the speaker was purchased. Further using the speaker may result in fire or electric shock.
 - If you detect smoke or a strange smell coming from the speaker
 - If water or any metallic object gets into the speaker
 - If the speaker falls, or the speaker case breaks
- To prevent a fire or electric shock, never open nor remove the speaker case. Refer all servicing to your nearest TOA dealer.

CAUTION

Indicates a potentially hazardous situation which, if mishandled, could result in moderate or minor personal injury, and/or property damage.

When Installing the Unit

- **Avoid touching the speaker's sharp metal edge to prevent injury.**
- **To avoid electric shocks, be sure to switch off the amplifier's power when connecting speakers.**

When the Unit is in Use

- Do not operate the speaker for an extended period of time with the sound distorting. Doing so may cause the speaker to heat, resulting in a fire.
- Do not stand or sit on, nor hang down from the speaker as this may cause it to fall down or drop, resulting in personal injury and/or property damage.
- Have the speaker checked periodically by the shop from where it was purchased. Failure to do so may result in corrosion or damage to the speaker or the mounts that could cause it to fall, possibly causing personal injury

2. GENERAL DESCRIPTION AND FEATURES

The PC-275AB-EB is certified according to the European Standard EN 54-24: 2008 and the International Standard ISO 7240-24: 2010.

Integrated with two speaker units, the PC-275AB-EB Ceiling Mount Speakers is of metallic construction and ideal for use in a voice alarm system. The spring catch mechanism allows easy speaker mounting to the ceiling. The input impedance can be easily selected by changing the tap position of the transformer. The screw terminal (steatite) makes input cable connections easy and allows bridge wiring.

This model features:

- Only 86 mm depth
- 2 separate 100 V transformer and 2 speaker
- 2 separate ceramic terminal blocks
- Quick-mount through U- shaped bracket
- Assembly with spring
- A/B wiring
- EN 54-24 certified + BS 5839 Part 8.

3. INSTALLATION

Step 1. Install a wire back box according the guideline of the manufacturer.

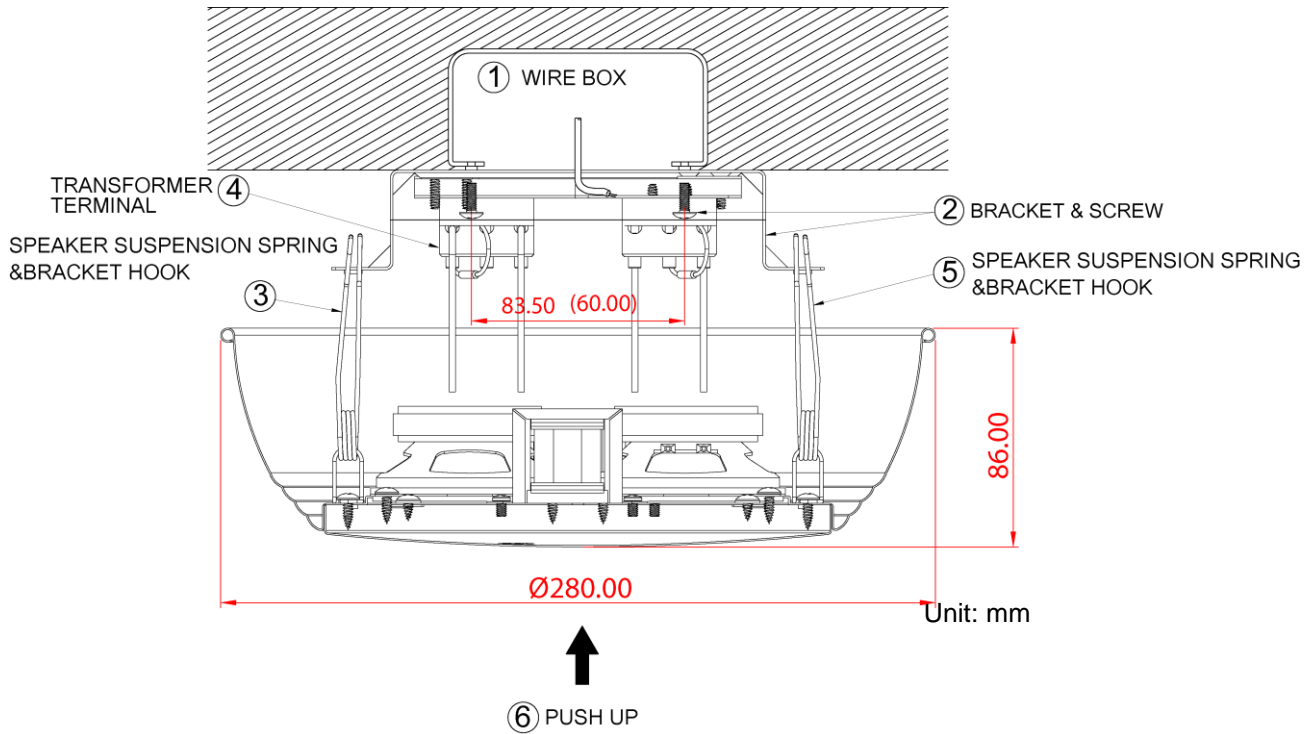

Step 2. Screw the speakers suspension bracket on the wire back box.

Step 3. Insert one of the speaker springs into the receptacle of the bracket.

Step 4. Make wiring.

Insert the lead-in cables (cables from the amplifier) and lead-out cables (cables to other speakers) into the screw terminals attached to the speaker unit for each of the two built-in speakers.

[PC-275AB-EB terminal block (1.67 kΩ use)]

• When no bridge connection is made

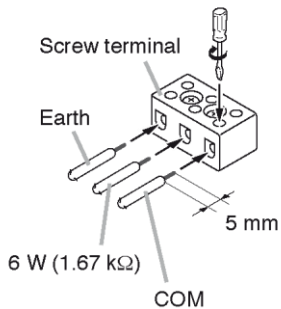

• When making a bridge connection

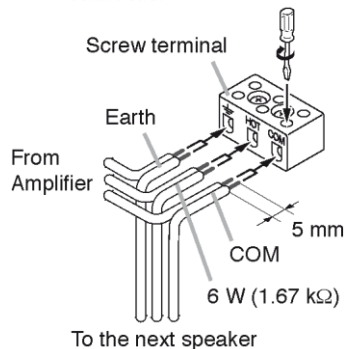

Insert the fasteners fitted at the ends of the HOT and COM cables from the screw terminals at the rear of the speaker unit into the taps of the matching transformer. Connect the COM cable to the transformer's COM tap, and the HOT cable to the desired transformer's input tap (Refer to the figure below).

The table below shows the relationship between impedance and input power.
Matching transformer connection

Impedance	1.67 kΩ	3.33 kΩ	6.67 kΩ
100 V line	6 W	3 W	1.5 W

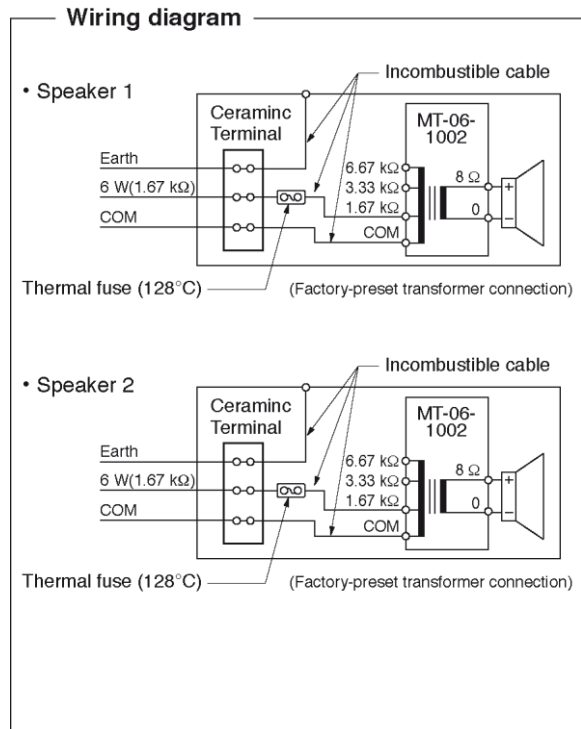

Step 5. Insert the other speaker spring into the receptacle of the fire dome

Step 6. Push the speaker upwards until it fits with the ceiling surface.

4. DIMENSIONAL DIAGRAM

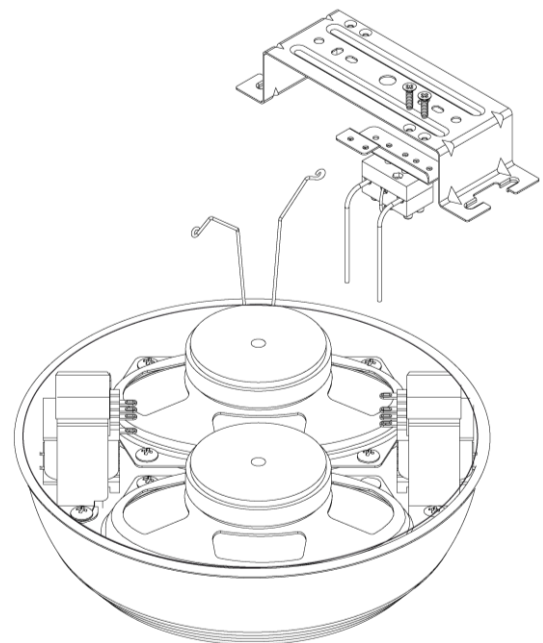
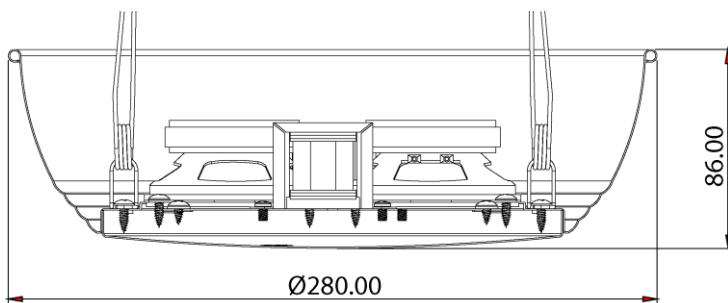

5. POLAR PATTERN

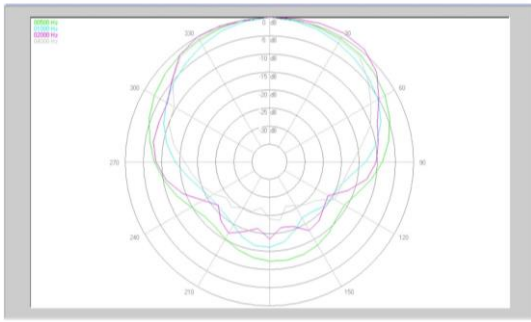

Horizontal polar diagram

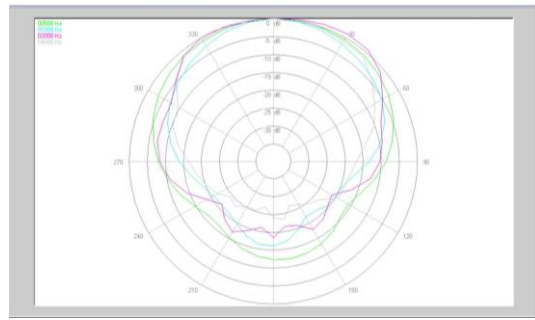

Vertical polar diagram

6. FREQUENCY RESPONSE (1 W, 1 m)



Single Speaker

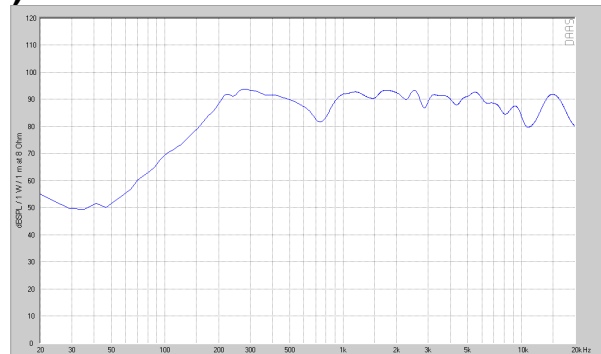

Double Speaker

7. SPECIFICATIONS

Model	PC-275AB-EB	
Standards	Certified to the European Standard EN 54-24: 2008 Loudspeaker for voice alarm systems for fire detection and fire alarm systems	EN 54-24 Certificate 1488/CPD/0337/W
	In compliance with the British Standard BS-5839-8: 2008	
Environment Type	Type A	
Rated Noise Power	2x 6 W (100 V line)	
Rated Impedance	100 V line: 1.67 kOhm (6 W), 3.33 kOhm (3 W), 6.67 kOhm (1.5 W)	
Sensitivity S.P.L.	92 dB (1 W, 1 m, 1 speaker) 100 dB (1 W, 1 m, 2 speaker)	
Frequency Response	180 Hz – 20 kHz (–10 dB from sensitivity)	
Coverage Angle (–6 dB)	Horizontal: 180° (500 Hz), 170° (1 kHz), 170° (2 kHz), 130° (4 kHz) Vertical: 180° (500 Hz), 155° (1 kHz), 130° (2 kHz), 135° (4 kHz)	
Speaker Component	2x: 8 x 12 cm (3"x 5") cone speaker	
Operating Temperature	-10°C + 55°C	
Cable Connection	Screw terminals (ceramic x 2)	
Applicable Cable Size	Conductor size : 0.8 – 2.5 mm ² (cross section)	
Finish	Baffle	Steel, white paint
	Cabinet	Steel, white paint
Dimensions	274.4 (dia) x 86.5 (D) mm (10.8" x 3.41")	
Weight	1.5 kg (3.31 lbs)	
IP Grade	IP 32	

Notes

- The design and specifications are subject to change without notice for improvement.
- The Specifications data was measured in an anechoic chamber, according to EN 54-24.
- Reference axis: Axis is on the center of grill surface and perpendicular to the grill surface.
- Reference plane: Plane is on the grill surface and perpendicular to the reference axis.
- Horizontal plane: Plane is containing the reference axis and perpendicular to the reference plane.